

P50 HWL

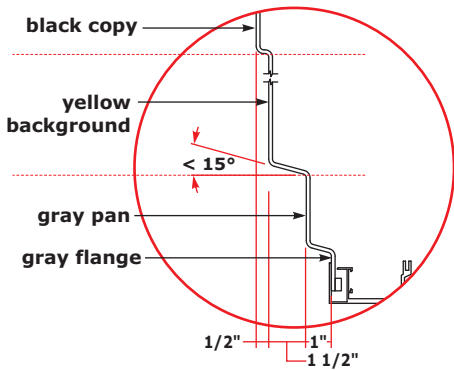
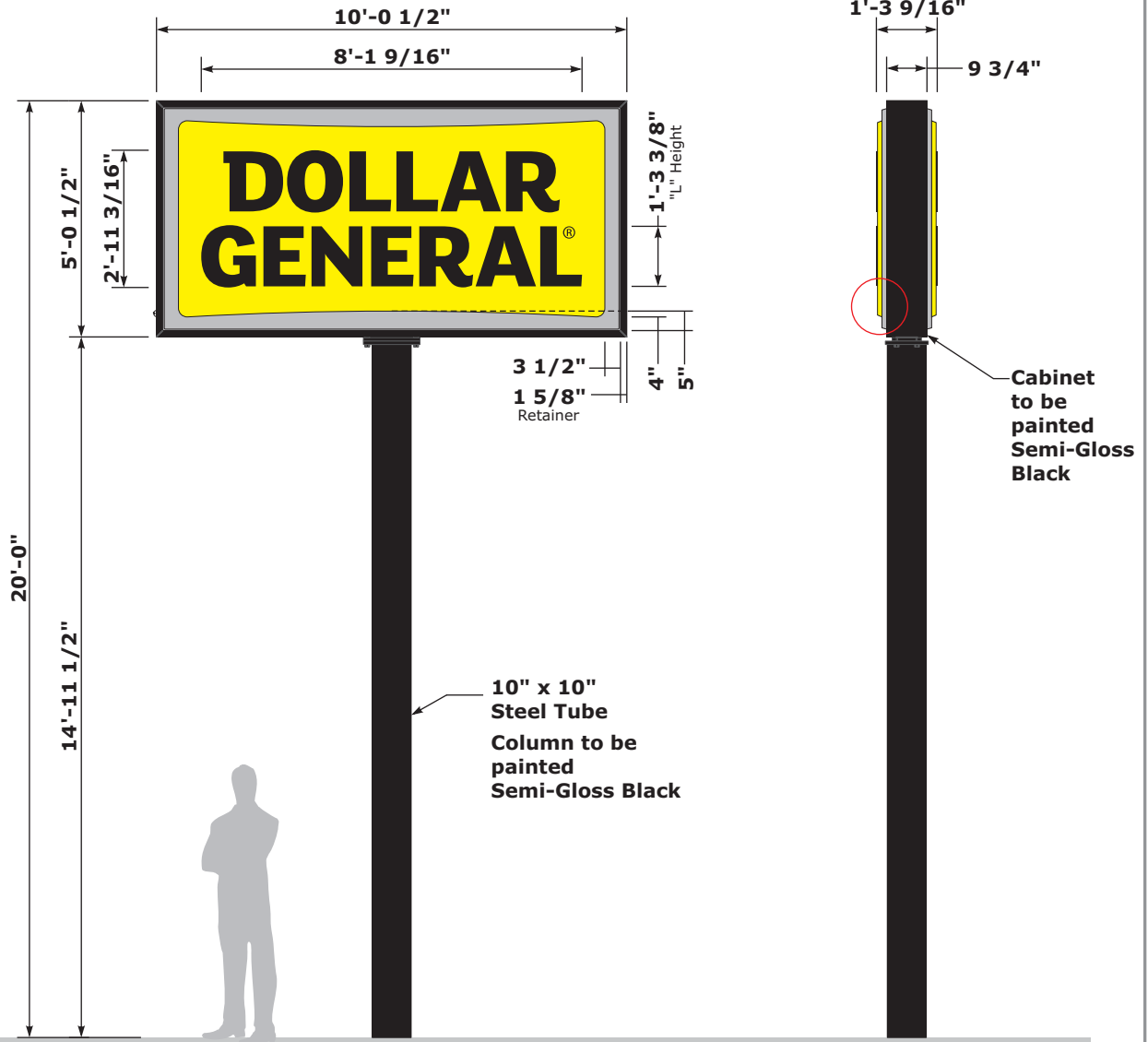

FACE EMBOSSMENT DETAIL

ELEVATION

SIDE

SQUARE FOOTAGE
ACTUAL
50.63 sq. ft.

COLOR SPECIFICATIONS	
Yellow:	match Spraylat C8-2633
Brushed Aluminum:	match Spraylat FM-171
Black (Copy):	match Spraylat Black
Semi-Gloss Black (Metal):	match Black Polyurethane
Cool Gray:	match PMS Cool Gray 5
Rock Bottom Gray:	match Sherwin Williams SW7062
Green:	match PMS 368C



File Name: Dollar General Cutsheets 2013	
Project #: 13-0181	Page 6 of 33
Date: 08/30/2013	
Approved By:	



135 SOUTH DAVID LANE  
KNOXVILLE, TN 37922  
OFFICE: 865-539-4001  
FAX: 865-539-0851  
WWW.LINKENGR.COM

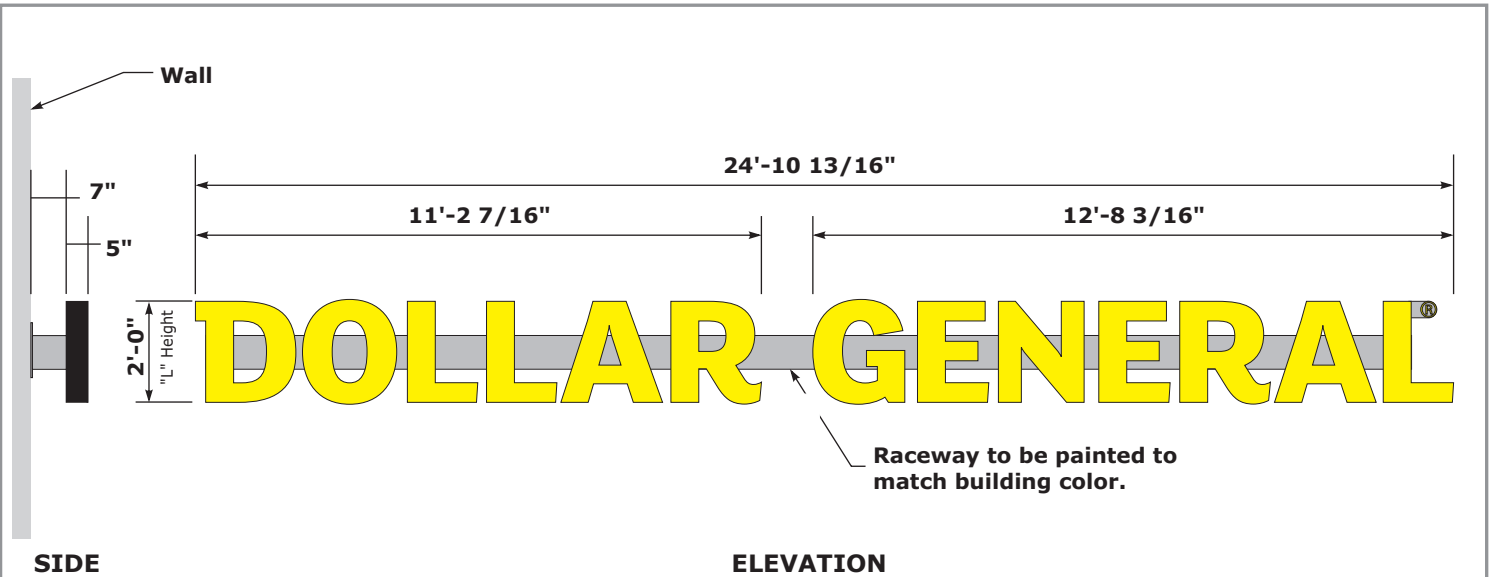

**3/16" Yellow #2037 acrylic face with Semi-Gloss Black returns.  
To be mounted to Signcomp 8" raceway.  
Illuminated with AgiLight White LED's.**

SQUARE FOOTAGE	
ACTUAL	BOXED METHOD
<b>DOLLAR GENERAL</b>	<b>DOLLAR GENERAL</b>
<b>27.72 sq. ft.</b>	<b>49.80 sq. ft.</b>

COLOR SPECIFICATIONS	
Yellow:	match Spraylat C8-2633
Brushed Aluminum:	match Spraylat FM-171
Black (Copy):	match Spraylat Black
Semi-Gloss Black (Metal):	match Black Polyurethane
Cool Gray:	match PMS Cool Gray 5
Rock Bottom Gray:	match Sherwin Williams SW7062
Green:	match PMS 368C



File Name: Dollar General Cutsheets 2013  
 Project #: 13-0181  
 Date: 08/30/2013  
 Approved By:



135 SOUTH DAVID LANE  
 KNOXVILLE, TN 37922  
 OFFICE: 865-539-4001  
 FAX: 865-539-0851  
 WWW.LINKENGR.COM

 **TRAFFIC IMPACT ANALYSIS**

# **DOLLAR GENERAL**

**JURISDICTION: CROOK COUNTY, OR  
LOCATION: SE JUNIPER CANYON RD, WEST OF BANTA LN**

*Prepared for:*  
**Keith Corporation**

*Prepared by:*  
**Kimley»»Horn**

January 2024  
090121001  
Copyright © Kimley-Horn and Associates, Inc.



## TRAFFIC IMPACT ANALYSIS

FOR

# DOLLAR GENERAL

**Prepared for:**  
Keith Corporation

**Prepared by:**  
Kimley-Horn and Associates, Inc.  
2828 Colby Avenue  
Suite 200  
Everett, Washington 98201  
(425) 708-8275



EXPIRES: 12/31/2024

*This document, together with the concepts and designs presented herein, as an instrument of service, is intended only for the specific purpose and client for which it was prepared. Reuse of and improper reliance on this document without written authorization and adaptation by Kimley-Horn and Associates, Inc. shall be without liability to Kimley-Horn and Associates, Inc.*

© January 2024  
090121001

**TABLE OF CONTENTS**

1. DEVELOPMENT IDENTIFICATION ..... 2  
 1.1. Scoping of Analysis..... 2  
 2. METHODOLOGY ..... 4  
 3. TRIP GENERATION ..... 5  
 4. TRIP DISTRIBUTION ..... 5  
 5. INTERSECTION LEVEL OF SERVICE ANALYSIS..... 8  
 5.1. Seasonal Adjustment Factor ..... 8  
 5.2. Turning Movement Calculations..... 9  
 5.3. Level of Service Calculations ..... 13  
 6. ACCESS ANALYSIS ..... 13  
 6.1. Site Access..... 13  
 6.2. Left Turn Lane Warrant ..... 14  
 7. CONCLUSIONS ..... 14

**LIST OF FIGURES**

Figure 1: Site Vicinity Map ..... 3  
 Figure 2: Development Trip Distribution – AM Peak-Hour..... 6  
 Figure 3: Development Trip Distribution – PM Peak-Hour..... 7  
 Figure 4: 2023 Existing Turning Movements – PM Peak-Hour..... 10  
 Figure 5: 2026 Baseline Turning Movements – PM Peak-Hour ..... 11  
 Figure 6: 2026 Future with Development Turning Movements – PM Peak-Hour ..... 12

**LIST OF TABLES**

Table 1: Level of Service Criteria ..... 4  
 Table 2. Trip Generation Summary..... 5  
 Table 3. Seasonal Adjustment Factor (ATR #07-001, Ochoco) ..... 8  
 Table 4: Level of Service Summary – PM Peak Hour ..... 13

**LIST OF APPENDICES**

EXISTING COUNT DATA AND GROWTH DATA ..... A  
 TURNING MOVEMENTS..... B  
 LEVEL OF SERVICE CALCULATIONS..... C  
 SITE PLAN..... D

## 1. DEVELOPMENT IDENTIFICATION

Kimley-Horn and Associates, Inc. (Kimley-Horn) has been retained to analyze the traffic impacts of the proposed Dollar General Development (Development). This report is intended to provide Crook County (County) and the Oregon Department of Transportation (ODOT) with the necessary traffic generation, trip distribution, and level of service analysis to facilitate their review of the Development. Brad Lincoln, responsible for this report and traffic analysis, is a licensed professional engineer (Civil) in the State of Oregon.



The Development is proposed to include a 12,687 square foot (SF) variety store. The Development is located on the south site of SE Juniper Canyon Road, west of Banta Lane. A site vicinity map is included in **Figure 1**. The site will access the county street network via one proposed access drive to the north of the site to connect with SE Juniper Canyon Road.

### 1.1. Scoping of Analysis

The analysis has been performed for the 2023 existing, 2026 baseline, and 2026 future with development conditions to account for full build-out of the site. The level of service analysis has been performed at the following intersections during the PM peak-hour based on scoping discussions with County staff:

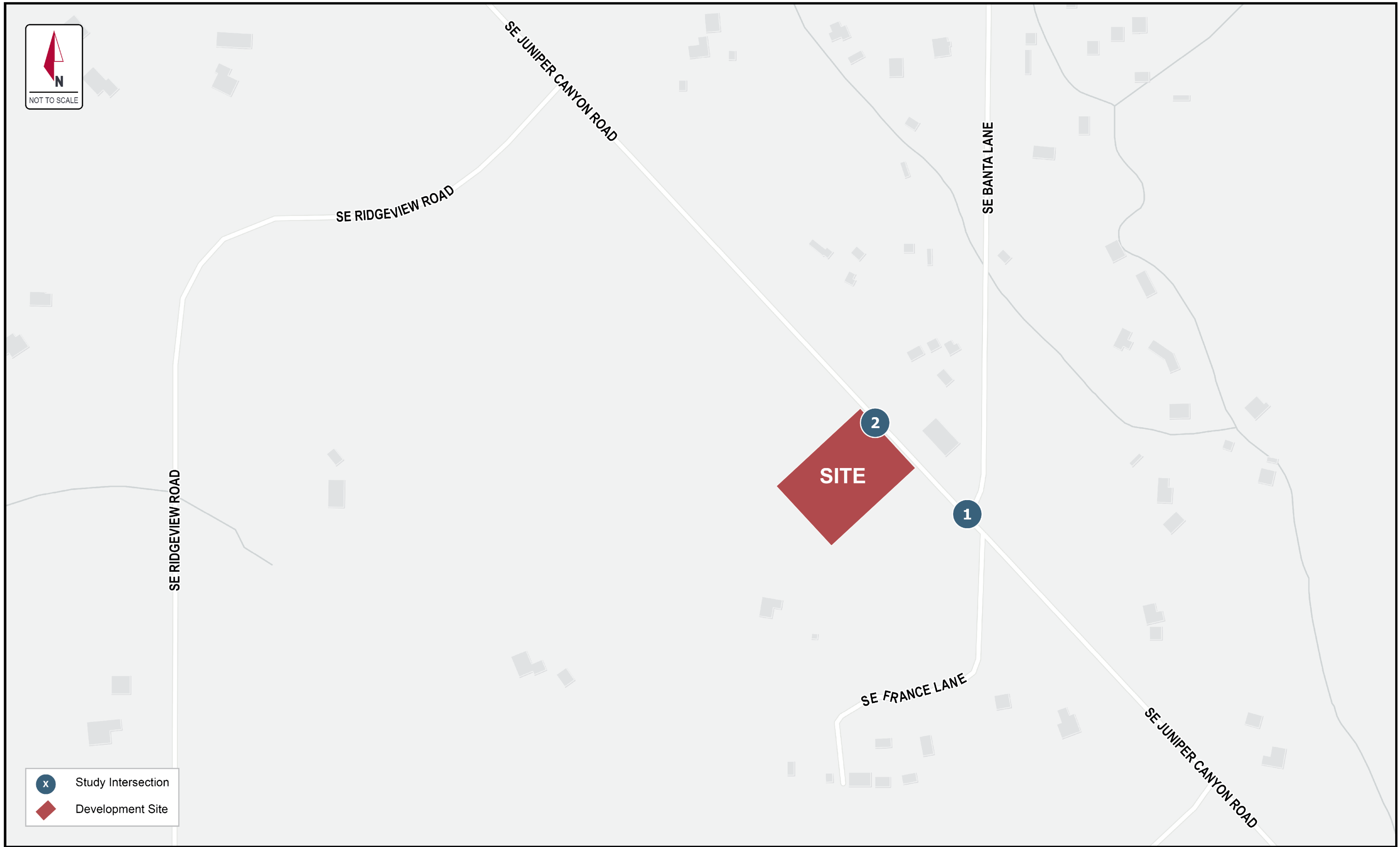
- SE Juniper Canyon Road at Banta Lane
- SE Juniper Canyon Road at Site Access (Future)



-  Study Intersection
-  Development Site

## 2. METHODOLOGY

Trip generation for the Development is based on national data contained in *Trip Generation Manual, 11<sup>th</sup> Edition (2021)* by the Institute of Transportation Engineers (ITE). The average rates for Land Use Code (LUC) 814, Variety Store, have been used in the trip generation calculations. The distribution of trips generated by the site is based on existing traffic volumes and surrounding land uses.

Congestion at intersections and along roadway is generally measured in terms of level of service (LOS). In accordance with *Highway Capacity Manual (HCM), 6<sup>th</sup> Edition* by the Transportation Research Board, road facilities and intersections are rated between LOS A and LOS F, with LOS A being free flow and LOS F being forced flow or over-capacity conditions. The LOS at signalized, roundabout, and all-way stop-controlled intersections is based on the average delay of all approaches. The LOS for two-way stop-controlled intersections is based on average delays for the critical stopped approach. Geometric characteristics and conflicting traffic movements are taken into consideration when determining LOS values. A summary of the intersection LOS criteria is included in **Table 1**.

**Table 1: Level of Service Criteria**

Level of Service <sup>1</sup>	Expected Delay	Intersection Control Delay (Seconds per Vehicle)	
		Unsignalized Intersections	Signalized Intersections
A	Little/No Delay	≤10	≤10
B	Short Delays	>10 and ≤15	>10 and ≤20
C	Average Delays	>15 and ≤25	>20 and ≤35
D	Long Delays	>25 and ≤35	>35 and ≤55
E	Very Long Delays	>35 and ≤50	>55 and ≤80
F	Extreme Delays <sup>2</sup>	>50	>80

Highway mobility standards specified in the Crook County Transportation System Plan (TSP) vary from a volume-to-capacity (v/c) ratio of 0.70 to 0.85 depending on the location within or outside the urban growth boundary (UGB). For evaluating operations of the existing configuration (including baseline and future analysis) the outside UGB rural lands standards are most appropriate, requiring a v/c ratio of 0.70.

<sup>1</sup> **Source:** *Highway Capacity Manual, 6<sup>th</sup> Edition*.

LOS A: Free-flow traffic conditions, with minimal delay to stopped vehicles (no vehicle is delayed longer than one cycle at signalized intersection).

LOS B: Generally stable traffic flow conditions.

LOS C: Occasional back-ups may develop but delay to vehicles is short term and still tolerable.

LOS D: During short periods of the peak hour, delays to approaching vehicles may be substantial but are tolerable during times of less demand (i.e., vehicles delayed one cycle or less at signal).

LOS E: Intersections operate at or near capacity, with long queues developing on all approaches and long delays.

LOS F: Jammed conditions on all approaches with excessively long delays and vehicles unable to move at times.

<sup>2</sup> When demand volume exceeds the capacity of the lane, extreme delays will be encountered with queuing which may cause severe congestion affecting other traffic movements in the intersection.



### 3. TRIP GENERATION

Trip generation calculations for the proposed Development have been performed using the ITE *Trip Generation Manual, 11<sup>th</sup> Edition (2021)*. The average rates for ITE LUC 814, Variety Store, have been used for the trip generation calculations. ITE LUC 814 is the most similar to the proposed use. The trips generated by the Development are summarized in **Table 2**.

**Table 2. Trip Generation Summary**

Variety Store 12,687 SF	Average Daily Trips (ADTs)			AM Peak-Hour Trips			PM Peak-Hour Trips		
	In	Out	Total	In	Out	Total	In	Out	Total
Generation Rate	63.66 trips per 1,000 SF			3.04 trips per 1,000 SF			6.70 trips per 1,000 SF		
Splits	50%	50%	100%	55%	45%	100%	51%	49%	100%
Trips	404	404	808	21	18	39	43	42	85

The Development is anticipated to generate approximately 808 ADTs with approximately 34 AM peak-hour trips and approximately 85 PM peak-hour trips.

### 4. TRIP DISTRIBUTION

The distribution of trips generated by the Development is primarily based on existing traffic patterns and surrounding land uses. The trip distribution is:

- 75% to and from the west along SE Juniper Canyon Road
- 25% to and from the east along SE Juniper Canyon Road

A detailed trip distribution for the AM peak-hour and PM peak-hour is displayed in **Figure 2** and **Figure 3**, respectively.

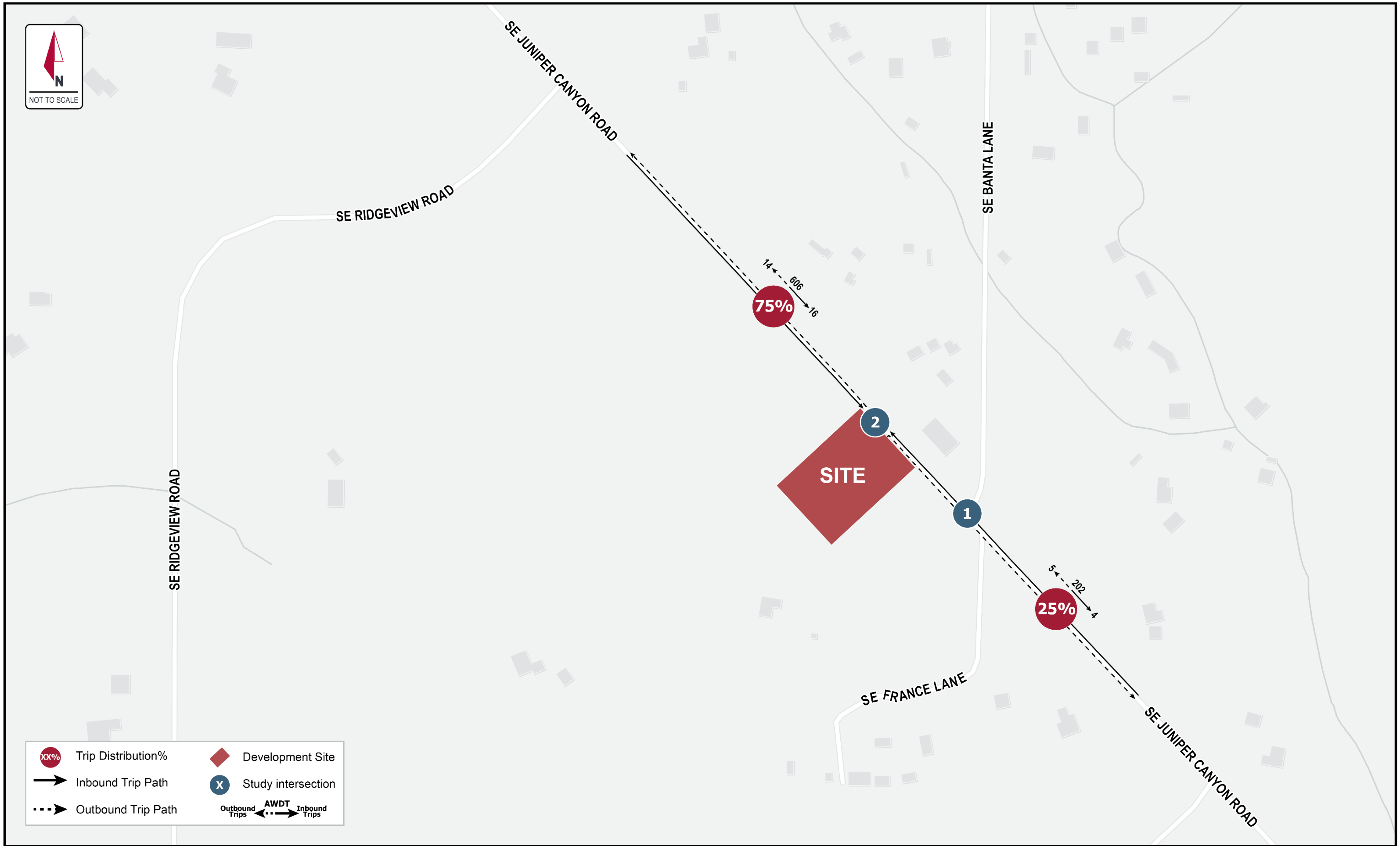
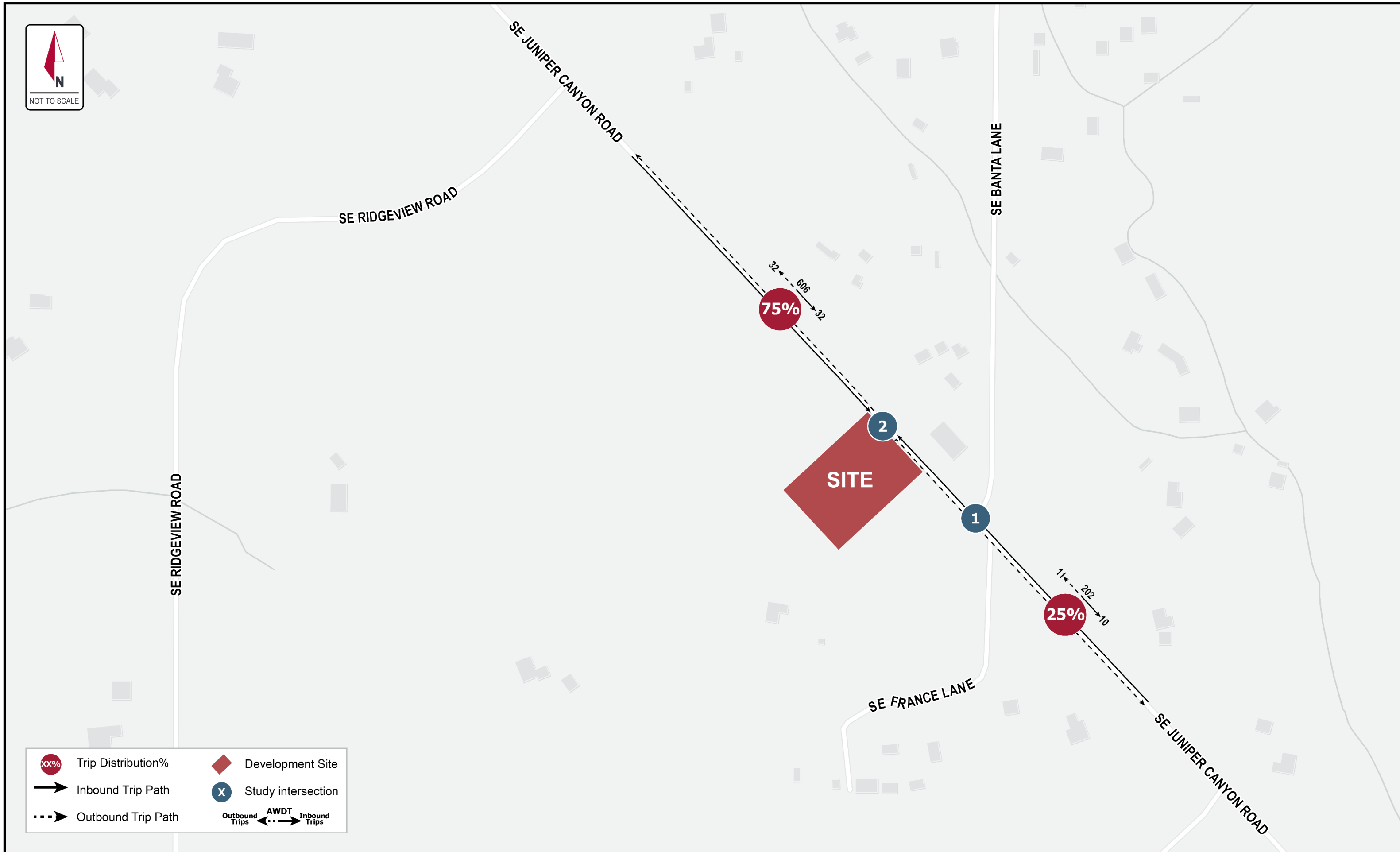

FIGURE 2 - AM PEAK PERIOD DEVELOPMENT TRIP DISTRIBUTION  
DOLLAR GENERAL - CROOK COUNTY, OR (090121001)



Trip Distribution%	Development Site
Inbound Trip Path	Study intersection
Outbound Trip Path	AWDT

FIGURE 3 - PM PEAK PERIOD DEVELOPMENT TRIP DISTRIBUTION  
**DOLLAR GENERAL - CROOK COUNTY, OR (090121001)**

## 5. INTERSECTION LEVEL OF SERVICE ANALYSIS

The following intersections have been analyzed as part of this report following scoping discussions with County staff:

- SE Juniper Canyon Road at Banta Lane
- SE Juniper Canyon Road at Site Access (Future)

The intersections have been analyzed for the weekday PM peak-hours (4-6pm) as requested by the County.

### 5.1. Seasonal Adjustment Factor

The 2023 existing traffic counts were modified to current 30<sup>th</sup> highest hourly volume (30HV) conditions by applying a seasonal adjustment factor consistent with ODOT’s Analysis Procedures Manual (APM). The seasonal adjustment factor was calculated using data collect at Automatic Tracking Recorder (ATR) #07-001, Ochoco. ATR #07-001 is located along Ochoco Highway No. 41, 2.03 miles west of Ochoco Dam.

Historical data at ATR #07-001 was analyzed to determine the peak-month beginning in 2018 through 2022. Within this five-year span, the ADT values were consistently higher than average weekday traffic (AWT). ADT was therefore used to determine the seasonal factors for ATR #07-001. The month of July had the highest ADT for four of five years of data. The month of July was therefore used when calculating seasonal adjustment factors for ATR #07-001. Following the APM process, the highest and lowest monthly percentages, highlighted in gray in **Table 3** below, were eliminated from the five-year historical data when calculating the average. The remaining three years of data were used to calculate the peak-month average for the five-year time period.

Counts were collected on November 9, 2023, and ATR data is reported for the 15<sup>th</sup> of each month. Therefore, the ADT values are near the mid-month data usually reported and thus no interpolation was used to calculate the ADT for November. The monthly percent of annual average daily traffic (AADT) for the peak-month of August and count month of November are shown in **Table 3**.

**Table 3. Seasonal Adjustment Factor (ATR #07-001, Ochoco)**

Year	2018	2019	2020	2021	2022	Average
Peak-Month (July)	131	136	135	123	128	131.33
Count Month (November)	85	85	84	87	80	84.67

For ATR #07-001, the average peak-month volume was 131.33 and the average count month volume was 84.67. This results in a seasonal factor of 1.55, calculated by dividing the peak-month average by the count month average.

## 5.2. Turning Movement Calculations

The existing PM peak-hour turning movements at the study intersections were collected by the independent count firm IDAX in November 2023. The seasonal factor of 1.55 from ATR #07-001 was applied to all existing peak-hour turning movement volumes to maintain the most conservative adjustment at the study intersections. The 2023 existing turning movements at the study intersections after the seasonal adjustment factors have been applied are shown in **Figure 4**. The existing count data is included in **Appendix A**.

The year 2026 was used to forecast future volume projections based on the anticipated completion of the Development. The 2026 baseline turning movements have been calculated by applying a 2.0% annually compounding growth rate to the 2023 existing turning movements. The AADT collected from existing permanent counters within the Oregon Traffic Monitoring System shows a negative growth rate along highways surrounding the site. Despite the lack of growth in the area, a 2.0% annual compounding growth rate has been applied to represent a conservatively high growth in the area. The permanent counter data is included in **Appendix A**. The 2026 baseline turning movements at the study intersections are shown in **Figure 5**.

The 2026 future with development turning movements at the study intersections have been calculated by adding the trips generated by the Development to the 2026 baseline turning movements. The 2026 future with development turning movements are shown in **Figure 6**. The turning movement calculations are included in **Appendix B**.



JUNIPER CANYON ROAD  
AT BANTA LANE

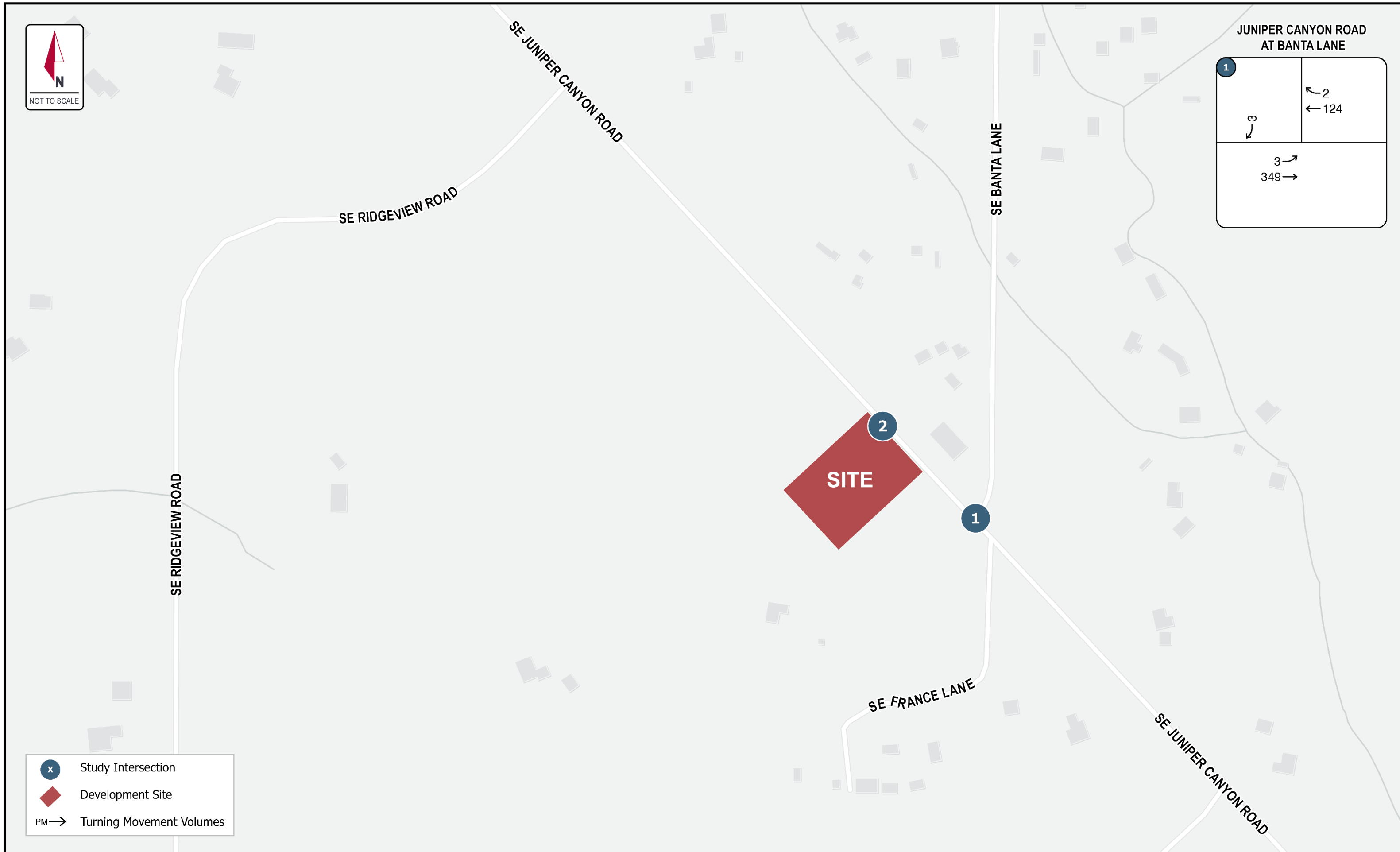
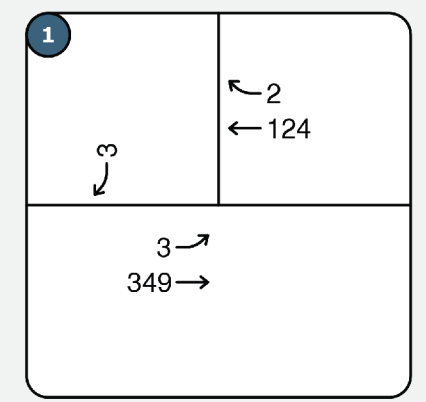

- Study Intersection
- Development Site
- PM → Turning Movement Volumes

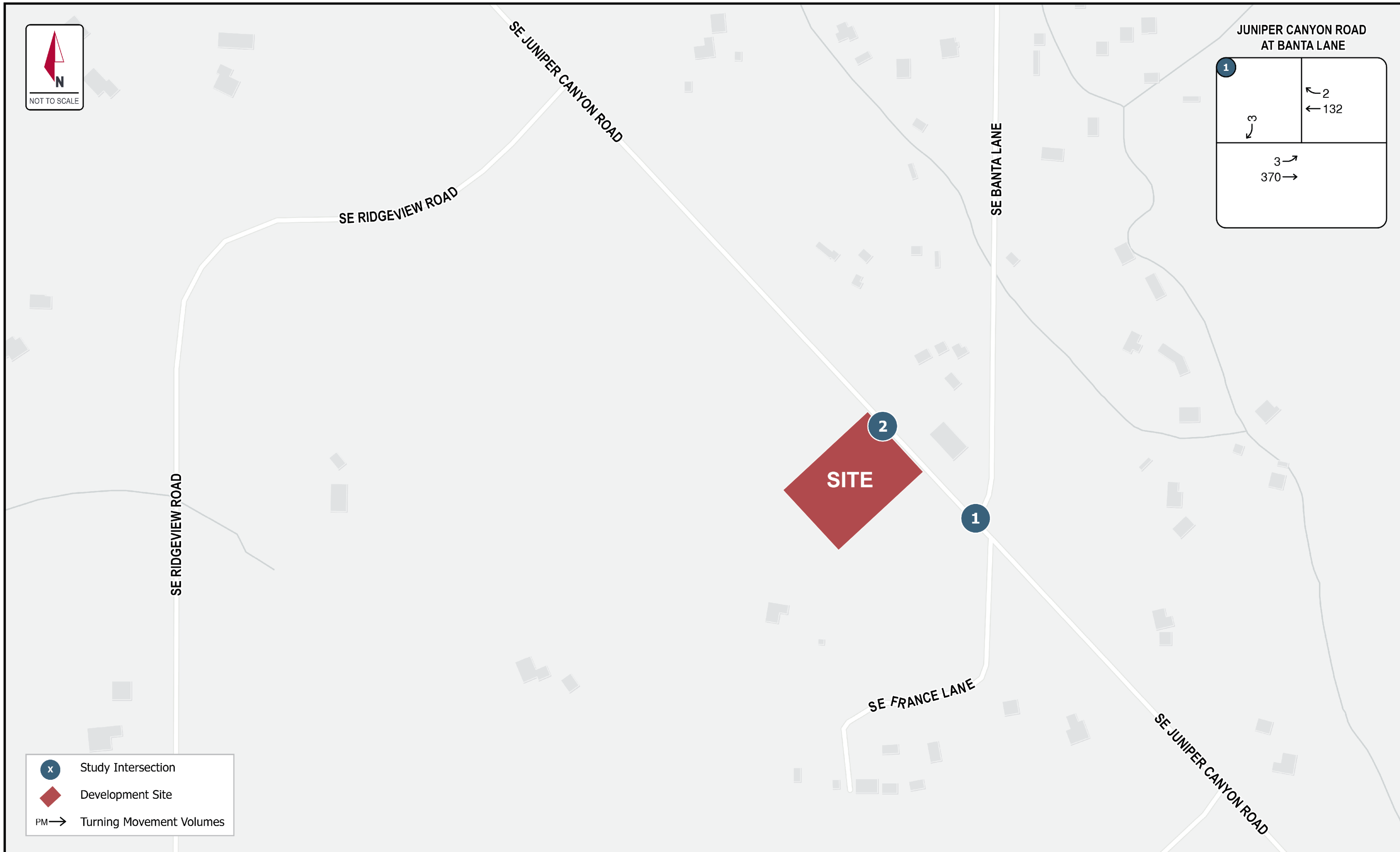
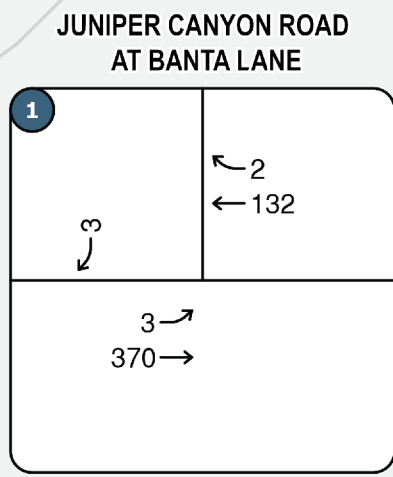

- Study Intersection
- Development Site
- PM → Turning Movement Volumes

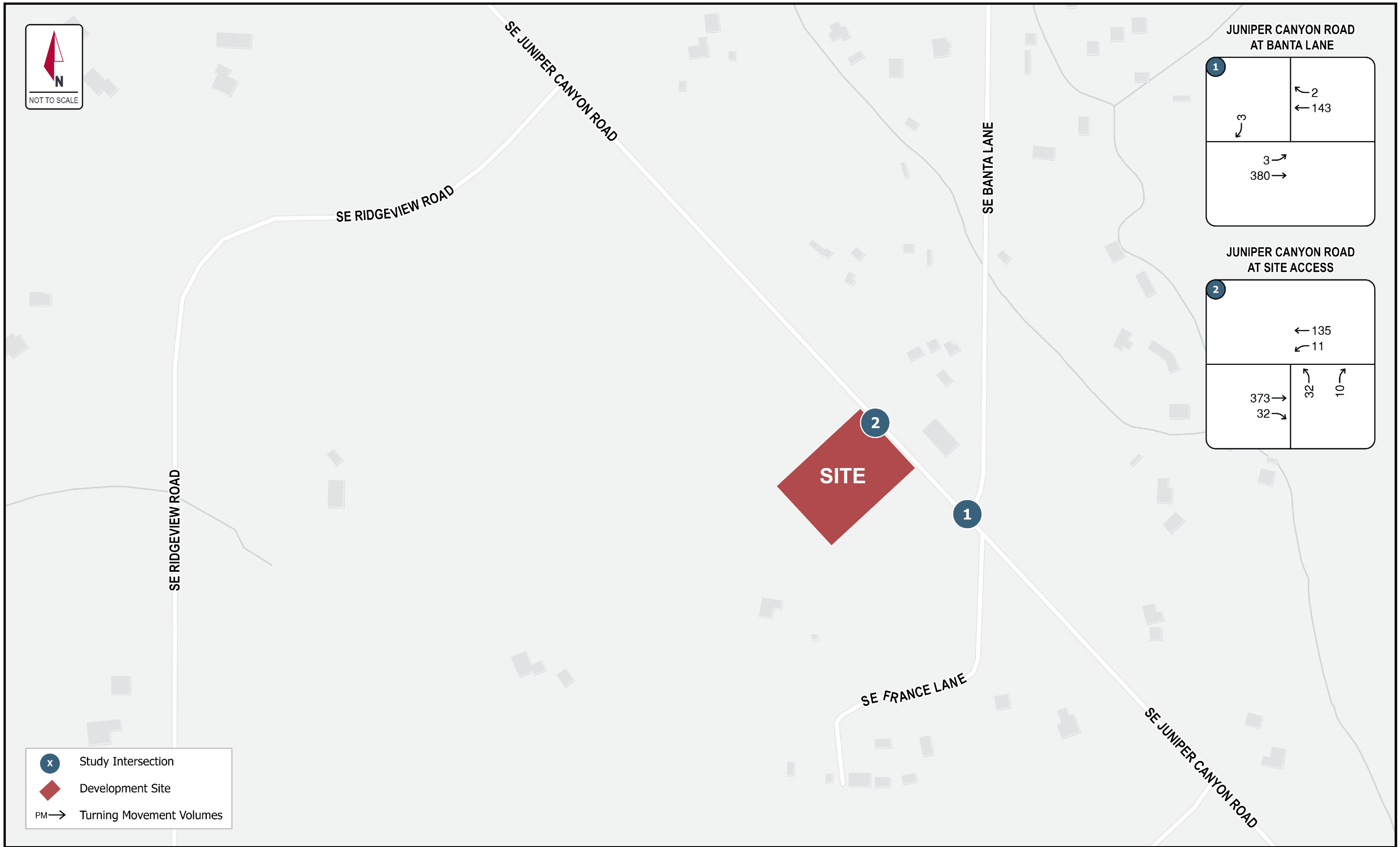

- Study Intersection
- Development Site
- PM → Turning Movement Volumes



### 5.3. Level of Service Calculations

The 2023 existing LOS calculations have been performed using the existing channelization, existing intersection control, and peak-hour factors and heavy vehicle factors from the 2023 turning movement counts. These parameters have been used for the 2023 existing, 2026 baseline, and 2026 future with development conditions. The LOS summary for the PM peak-hour is included in **Table 4**.

*Table 4: Level of Service Summary – PM Peak Hour*

Intersection	Control	2023 Existing Conditions		2026 Baseline Conditions		2026 Future w. Development Conditions	
		LOS	Delay Approach	LOS	Delay Approach	LOS	Delay Approach
1. SE Juniper Canyon Road at Banta Lane	Two-Way Stop Control	A	9.0 sec 0.004 v/c	A	9.0 sec 0.004 v/c	A	9.1 sec 0.004 v/c
2. SE Juniper Canyon Road at Site Access	Two-Way Stop Control	---	---	---	---	B	13.0 sec 0.09 v/c

The analysis shows all off-site study intersection currently operates at an acceptable LOS and is anticipated to continue operating at an acceptable LOS under the baseline and future with development conditions. The site access is also anticipated to operate acceptably without additional channelization. The intersection LOS calculations are provided in the **Appendix C**.

## 6. ACCESS ANALYSIS

### 6.1. Site Access

The Development is proposing to construct a new access approximately 500 feet west of Banta Lane along the south side of SE Juniper Canyon Road. The County has a spacing requirement between adjacent intersections of half a mile (centerline-to-centerline) for local access roadways. The Development’s proposed access location cannot meet this spacing from Banta Lane due to the lack of available frontage. The site access is expected to operate acceptably with a single outbound lane, separate left/right turn lanes will not be required.

The stopping and intersection sight distances were evaluated using the American Association of State Highway and Transportation Officials (AASHTO). SE Juniper Canyon Road does not have a posted speed limit in the site vicinity, but there are other locations along the roadway that appear to have a posted speed limit of 55 miles per hour (mph). A 55-mph speed corresponds to stopping and intersection sight distances of 495 feet and 610 feet, respectively. The Development’s access is expected to meet these stopping and entering sight distances.

## 6.2. Left Turn Lane Warrant

The channelization along SE Juniper Canyon Road, which is a currently a two-lane roadway, was also evaluated. ODOT channelization criteria were used to determine if westbound left-turn channelization is warranted along SE Juniper Canyon Road at the site access. The left-turn warrant is based on ODOT's *Analysis Procedures Manual, Unsignalized Intersection Analysis* criteria, specifically *Exhibit 1201 Left Turn Lane Criterion*. The future with development PM peak-hour turning movement volumes were used to analyze the warrant. There are anticipated to be 11 left-turns at the site access and 551 opposing plus advancing volumes. These volumes do not warrant a signal based on a speed of greater than or equal to 55 mph. A left-turn lane should therefore not be needed at the site access.

## 7. CONCLUSIONS

The Development is proposed to include a 12,687 SF variety store. The Development is located along the south side of SE Juniper Canyon Road, west of Banta Lane. The Development is anticipated to generate approximately 808 ADTs with approximately 39 AM peak-hour trips and approximately 85 PM peak-hour trips. The study intersections currently operate acceptably and are anticipated to operate at acceptable levels of service under the 2026 future with development conditions. A left turn lane should not be warranted due to the low volume of westbound left turns and opposing through traffic.

**APPENDIX A**  
**EXISTING COUNT DATA AND GROWTH DATA**

## Banta Ln SE Juniper Canyon Rd



Date: 11/09/2023  
Count Period: 4:00 PM to 6:00 PM  
Peak Hour: 4:00 PM to 5:00 PM

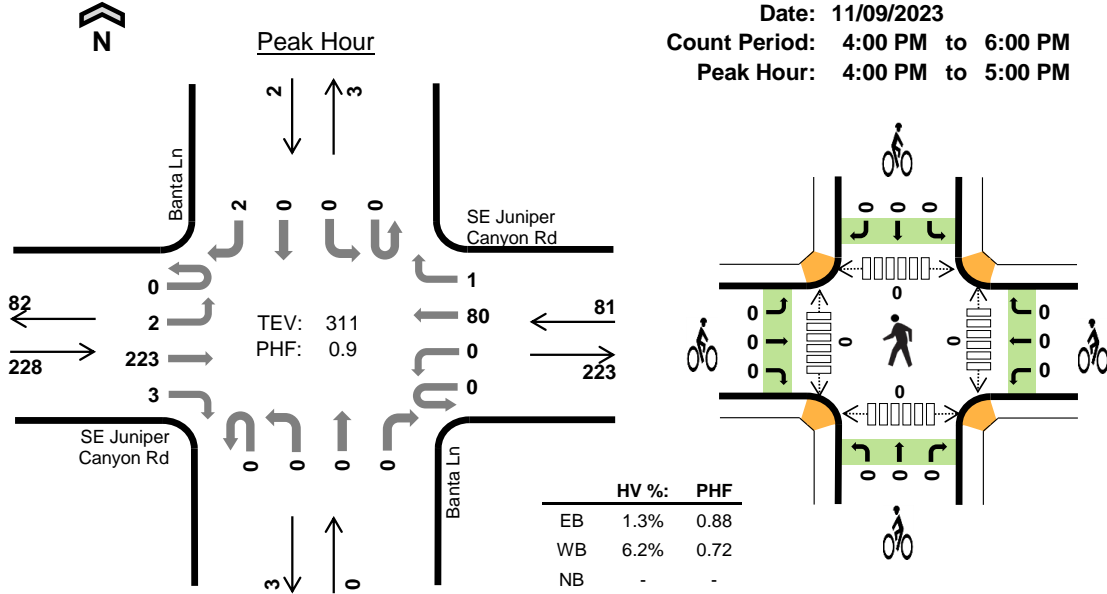

### Two-Hour Count Summaries

Interval Start	SE Juniper Canyon Rd				SE Juniper Canyon Rd				Banta Ln				Banta Ln				15-min Total	Rolling One Hour	
	Eastbound		Westbound		Northbound		Southbound		Northbound		Southbound								
	UT	LT	TH	RT	UT	LT	TH	RT	UT	LT	TH	RT	UT	LT	TH	RT			
4:00 PM	0	1	48	0	0	0	28	0	0	0	0	0	0	0	0	1	78	0	
4:15 PM	0	0	61	0	0	0	19	0	0	0	0	0	0	0	0	0	80	0	
4:30 PM	0	1	62	2	0	0	21	0	0	0	0	0	0	0	0	0	86	0	
4:45 PM	0	0	52	1	0	0	12	1	0	0	0	0	0	0	0	1	67	311	
5:00 PM	0	0	41	0	0	0	11	0	0	0	0	0	0	0	0	0	52	285	
5:15 PM	0	1	36	0	0	0	17	0	0	0	0	0	0	0	0	0	54	259	
5:30 PM	0	3	60	0	0	0	12	1	0	0	0	0	0	0	0	0	76	249	
5:45 PM	0	2	30	0	0	0	9	0	0	0	0	0	0	0	0	0	41	223	
Count Total	0	8	390	3	0	0	129	2	0	0	0	0	0	0	0	2	534	0	
Peak Hour	All	0	2	223	3	0	0	80	1	0	0	0	0	0	0	0	2	311	0
	HV	0	0	3	0	0	0	5	0	0	0	0	0	0	0	0	0	8	0
	HV%	-	0%	1%	0%	-	-	6%	0%	-	-	-	-	-	-	-	0%	3%	0

Note: Two-hour count summary volumes include heavy vehicles but exclude bicycles in overall count.

Interval Start	Heavy Vehicle Totals					Bicycles					Pedestrians (Crossing Leg)				
	EB	WB	NB	SB	Total	EB	WB	NB	SB	Total	East	West	North	South	Total
4:00 PM	2	1	0	0	3	0	0	0	0	0	0	0	0	0	0
4:15 PM	1	1	0	0	2	0	0	0	0	0	0	0	0	0	0
4:30 PM	0	3	0	0	3	0	0	0	0	0	0	0	0	0	0
4:45 PM	0	0	0	0	0	0	0	0	0	0	0	0	0	0	0
5:00 PM	0	0	0	0	0	0	0	0	0	0	0	0	0	0	0
5:15 PM	0	0	0	0	0	0	0	0	0	0	0	0	0	0	0
5:30 PM	1	0	0	0	1	0	0	0	0	0	0	0	0	0	0
5:45 PM	0	0	0	0	0	0	0	0	0	0	0	0	0	0	0
Count Total	4	5	0	0	9	0	0	0	0	0	0	0	0	0	0
Peak Hour	3	5	0	0	8	0	0	0	0	0	0	0	0	0	0

Project: Dollar General - Crook County  
 Subject: ODOT Growth Rate Calculations  
 Designed By: KH analyst

Project Number: 00121001  
 Date: 12/14/2023  
 Page: 1 of 1

**Existing Growth Rate Calculations**

Ref: Oregon Department of Transportation - Transportation Data Management System 2022

Number of Count Stations Analyzed = 4

Average Annual Growth Rate in the Vicinity of the Proposed Project = -0.51%

ODOT COUNT STATION:	4477	
ROADWAY:	Paulina Highway No. 380	
LOCATION:	0.05 miles southeast of Juniper Canyon Road	
Year	ADT	Annual Growth Rate
2018	1026	-4.23%
2022	863	
YEARS =	4	
PROJECTED TRAFFIC VOLUMES		
Year	ADT	
2023	826	
2024	791	
2025	758	

ODOT COUNT STATION:	4478	
ROADWAY:	Paulina Highway No. 380	
LOCATION:	0.02 miles west of road to rock quarry	
Year	ADT	Annual Growth Rate
2018	406	1.51%
2022	431	
YEARS =	4	
PROJECTED TRAFFIC VOLUMES		
Year	ADT	
2023	437	
2024	444	
2025	451	

ODOT COUNT STATION:	4475	
ROADWAY:	Paulina Highway No. 380	
LOCATION:	0.05 miles southeast of Carey Foster Road	
Year	ADT	Annual Growth Rate
2018	7165	-0.77%
2022	6946	
YEARS =	4	
PROJECTED TRAFFIC VOLUMES		
Year	ADT	
2023	6652	
2024	6370	
2025	6101	

ODOT COUNT STATION:	4479	
ROADWAY:	Paulina Highway No. 380	
LOCATION:	0.02 miles north of Crooked River Road	
Year	ADT	Annual Growth Rate
2018	388	1.45%
2022	411	
YEARS =	4	
PROJECTED TRAFFIC VOLUMES		
Year	ADT	
2023	417	
2024	423	
2025	430	

**APPENDIX B**  
**TURNING MOVEMENTS**

Synchro ID: 1  
**Existing**  
 Average Weekday  
 PM Peak-Hour

Year: 11/9/2023

Data Source: IDAX

Three (3) eastbound right-turns  
 have been added to the  
 eastbound through volumes.

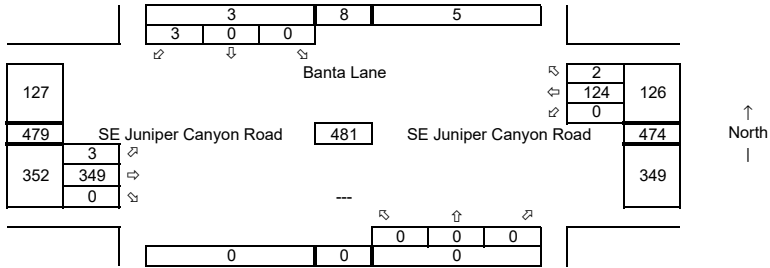

**Future without Development**  
 Average Weekday  
 PM Peak-Hour

Year: 2026  
 Growth Rate = 2.0%  
 Years of Growth = 3  
 Total Growth = 1.0612

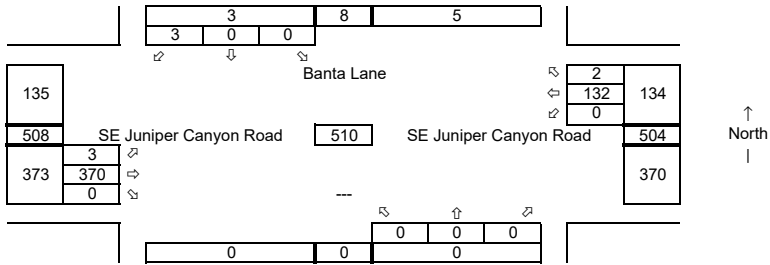

**Total Development Trips**  
 Average Weekday  
 PM Peak-Hour

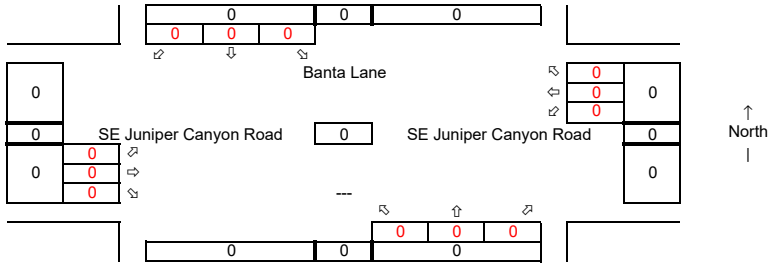

**Future with Development**  
 Average Weekday  
 PM Peak-Hour

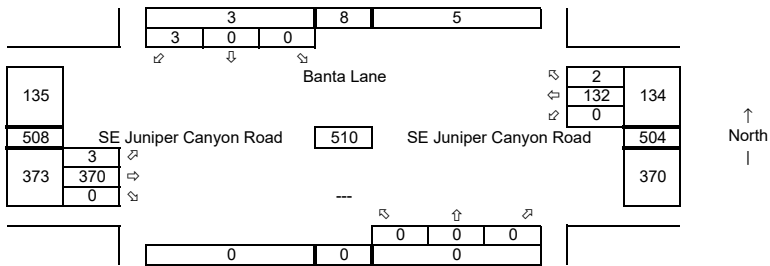

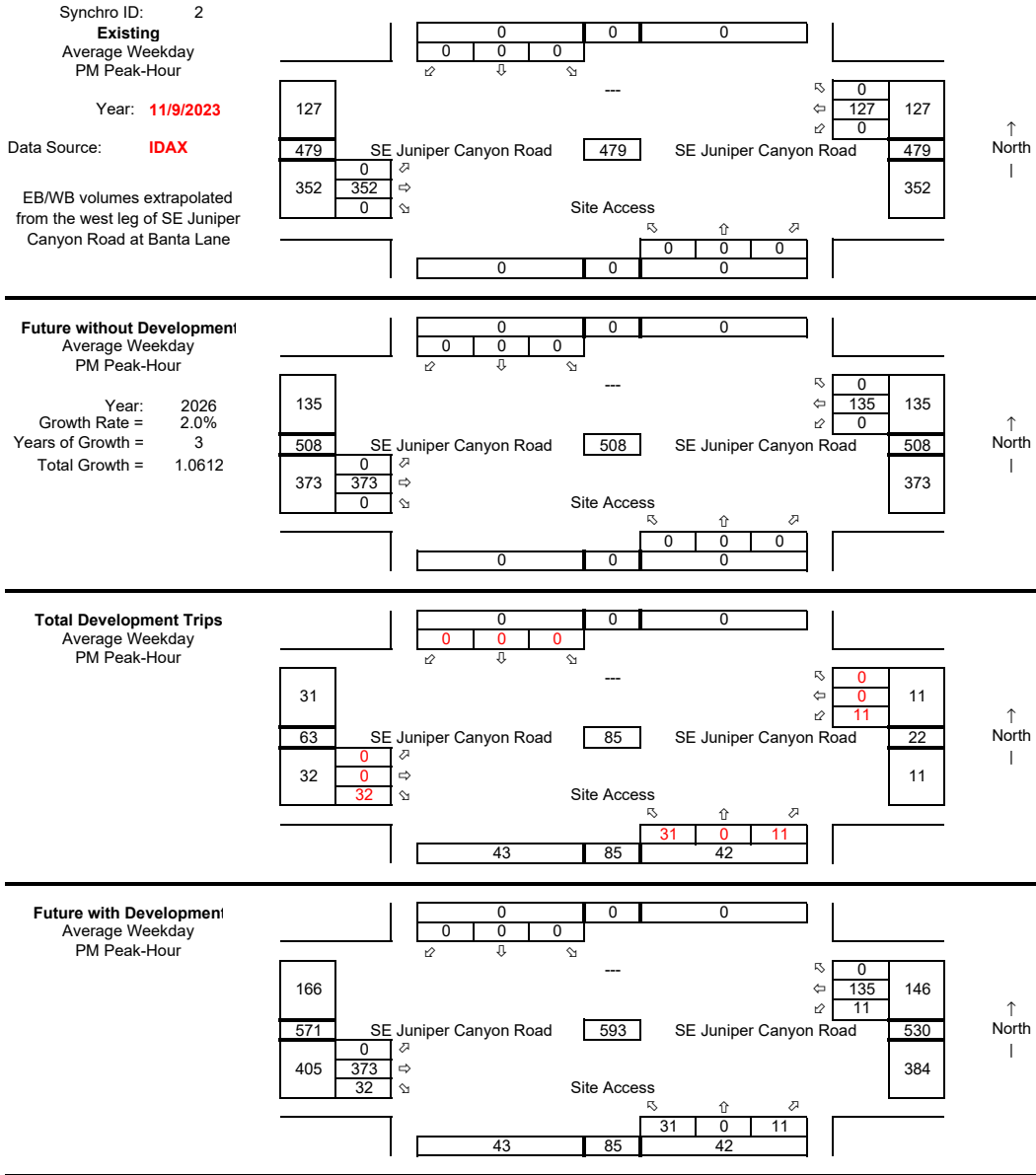



**APPENDIX C**  
**LEVEL OF SERVICE CALCULATIONS**

HCM 6th TWSC  
 1: SE Juniper Canyon Road & Banta Lane

2023 EXISTING CONDITIONS

Intersection

Int Delay, s/veh	0.1					
Movement	EBL	EBT	WBT	WBR	SBL	SBR
Lane Configurations		←	←			←
Traffic Vol, veh/h	3	349	124	2	0	3
Future Vol, veh/h	3	349	124	2	0	3
Conflicting Peds, #/hr	0	0	0	0	0	0
Sign Control	Free	Free	Free	Free	Stop	Stop
RT Channelized	-	None	-	None	-	None
Storage Length	-	-	-	-	-	0
Veh in Median Storage, #	-	0	0	-	0	-
Grade, %	-	0	0	-	0	-
Peak Hour Factor	90	90	90	90	90	90
Heavy Vehicles, %	3	3	3	3	3	3
Mvmt Flow	3	388	138	2	0	3

Major/Minor	Major1	Major2	Minor2
Conflicting Flow All	140	0	0
Stage 1	-	-	-
Stage 2	-	-	-
Critical Hdwy	4.13	-	-
Critical Hdwy Stg 1	-	-	-
Critical Hdwy Stg 2	-	-	-
Follow-up Hdwy	2.227	-	-
Pot Cap-1 Maneuver	1437	-	0
Stage 1	-	-	0
Stage 2	-	-	0
Platoon blocked, %	-	-	-
Mov Cap-1 Maneuver	1437	-	-
Mov Cap-2 Maneuver	-	-	-
Stage 1	-	-	-
Stage 2	-	-	-

Approach	EB	WB	SB
HCM Control Delay, s	0.1	0	9
HCM LOS			A

Minor Lane/Major Mvmt	EBL	EBT	WBT	WBR	SBLn1
Capacity (veh/h)	1437	-	-	-	907
HCM Lane V/C Ratio	0.002	-	-	-	0.004
HCM Control Delay (s)	7.5	0	-	-	9
HCM Lane LOS	A	A	-	-	A
HCM 95th %tile Q(veh)	0	-	-	-	0

HCM 6th TWSC  
 1: SE Juniper Canyon Road & Banta Lane

2026 BASELINE CONDITIONS

Intersection

Int Delay, s/veh	0.1					
Movement	EBL	EBT	WBT	WBR	SBL	SBR
Lane Configurations		↔	↔			↔
Traffic Vol, veh/h	3	370	132	2	0	3
Future Vol, veh/h	3	370	132	2	0	3
Conflicting Peds, #/hr	0	0	0	0	0	0
Sign Control	Free	Free	Free	Free	Stop	Stop
RT Channelized	-	None	-	None	-	None
Storage Length	-	-	-	-	-	0
Veh in Median Storage, #	-	0	0	-	0	-
Grade, %	-	0	0	-	0	-
Peak Hour Factor	90	90	90	90	90	90
Heavy Vehicles, %	3	3	3	3	3	3
Mvmt Flow	3	411	147	2	0	3

Major/Minor	Major1	Major2	Minor2		
Conflicting Flow All	149	0	-	0	- 148
Stage 1	-	-	-	-	-
Stage 2	-	-	-	-	-
Critical Hdwy	4.13	-	-	-	- 6.23
Critical Hdwy Stg 1	-	-	-	-	-
Critical Hdwy Stg 2	-	-	-	-	-
Follow-up Hdwy	2.227	-	-	-	- 3.327
Pot Cap-1 Maneuver	1426	-	-	-	0 896
Stage 1	-	-	-	-	0 -
Stage 2	-	-	-	-	0 -
Platoon blocked, %	-	-	-	-	-
Mov Cap-1 Maneuver	1426	-	-	-	- 896
Mov Cap-2 Maneuver	-	-	-	-	-
Stage 1	-	-	-	-	-
Stage 2	-	-	-	-	-

Approach	EB	WB	SB
HCM Control Delay, s	0.1	0	9
HCM LOS			A

Minor Lane/Major Mvmt	EBL	EBT	WBT	WBR	SBLn1
Capacity (veh/h)	1426	-	-	-	896
HCM Lane V/C Ratio	0.002	-	-	-	0.004
HCM Control Delay (s)	7.5	0	-	-	9
HCM Lane LOS	A	A	-	-	A
HCM 95th %tile Q(veh)	0	-	-	-	0

HCM 6th TWSC  
 1: SE Juniper Canyon Road & Banta Lane

2026 FUTURE WITH DEVELOPMENT CONDITIONS

Intersection

Int Delay, s/veh	0.1					
Movement	EBL	EBT	WBT	WBR	SBL	SBR
Lane Configurations		↔	↔			↔
Traffic Vol, veh/h	3	380	143	2	0	3
Future Vol, veh/h	3	380	143	2	0	3
Conflicting Peds, #/hr	0	0	0	0	0	0
Sign Control	Free	Free	Free	Free	Stop	Stop
RT Channelized	-	None	-	None	-	None
Storage Length	-	-	-	-	-	0
Veh in Median Storage, #	-	0	0	-	0	-
Grade, %	-	0	0	-	0	-
Peak Hour Factor	90	90	90	90	90	90
Heavy Vehicles, %	3	3	3	3	3	3
Mvmt Flow	3	422	159	2	0	3

Major/Minor	Major1	Major2	Minor2
Conflicting Flow All	161	0	0
Stage 1	-	-	-
Stage 2	-	-	-
Critical Hdwy	4.13	-	-
Critical Hdwy Stg 1	-	-	-
Critical Hdwy Stg 2	-	-	-
Follow-up Hdwy	2.227	-	-
Pot Cap-1 Maneuver	1412	-	0
Stage 1	-	-	0
Stage 2	-	-	0
Platoon blocked, %	-	-	-
Mov Cap-1 Maneuver	1412	-	-
Mov Cap-2 Maneuver	-	-	-
Stage 1	-	-	-
Stage 2	-	-	-

Approach	EB	WB	SB
HCM Control Delay, s	0.1	0	9.1
HCM LOS			A

Minor Lane/Major Mvmt	EBL	EBT	WBT	WBR	SBLn1
Capacity (veh/h)	1412	-	-	-	882
HCM Lane V/C Ratio	0.002	-	-	-	0.004
HCM Control Delay (s)	7.6	0	-	-	9.1
HCM Lane LOS	A	A	-	-	A
HCM 95th %tile Q(veh)	0	-	-	-	0

HCM 6th TWSC  
 2: Site Access & SE Juniper Canyon Road

2026 FUTURE WITH DEVELOPMENT CONDITIONS

Intersection						
Int Delay, s/veh	1.1					
Movement	EBT	EBR	WBL	WBT	NBL	NBR
Lane Configurations						
Traffic Vol, veh/h	373	32	11	135	32	10
Future Vol, veh/h	373	32	11	135	32	10
Conflicting Peds, #/hr	0	0	0	0	0	0
Sign Control	Free	Free	Free	Free	Stop	Stop
RT Channelized	-	None	-	None	-	None
Storage Length	-	-	-	-	0	-
Veh in Median Storage, #	0	-	-	0	0	-
Grade, %	0	-	-	0	0	-
Peak Hour Factor	92	92	92	92	92	92
Heavy Vehicles, %	2	2	2	2	2	2
Mvmt Flow	405	35	12	147	35	11

Major/Minor	Major1	Major2	Minor1		
Conflicting Flow All	0	0	440	0	594
Stage 1	-	-	-	-	423
Stage 2	-	-	-	-	171
Critical Hdwy	-	-	4.12	-	6.42
Critical Hdwy Stg 1	-	-	-	-	5.42
Critical Hdwy Stg 2	-	-	-	-	5.42
Follow-up Hdwy	-	-	2.218	-	3.518
Pot Cap-1 Maneuver	-	-	1120	-	468
Stage 1	-	-	-	-	661
Stage 2	-	-	-	-	859
Platoon blocked, %	-	-	-	-	-
Mov Cap-1 Maneuver	-	-	1120	-	462
Mov Cap-2 Maneuver	-	-	-	-	462
Stage 1	-	-	-	-	661
Stage 2	-	-	-	-	849

Approach	EB	WB	NB
HCM Control Delay, s	0	0.6	13
HCM LOS			B

Minor Lane/Major Mvmt	NBLn1	EBT	EBR	WBL	WBT
Capacity (veh/h)	493	-	-	1120	-
HCM Lane V/C Ratio	0.093	-	-	0.011	-
HCM Control Delay (s)	13	-	-	8.2	0
HCM Lane LOS	B	-	-	A	A
HCM 95th %tile Q(veh)	0.3	-	-	0	-

**APPENDIX D**  
**SITE PLAN**

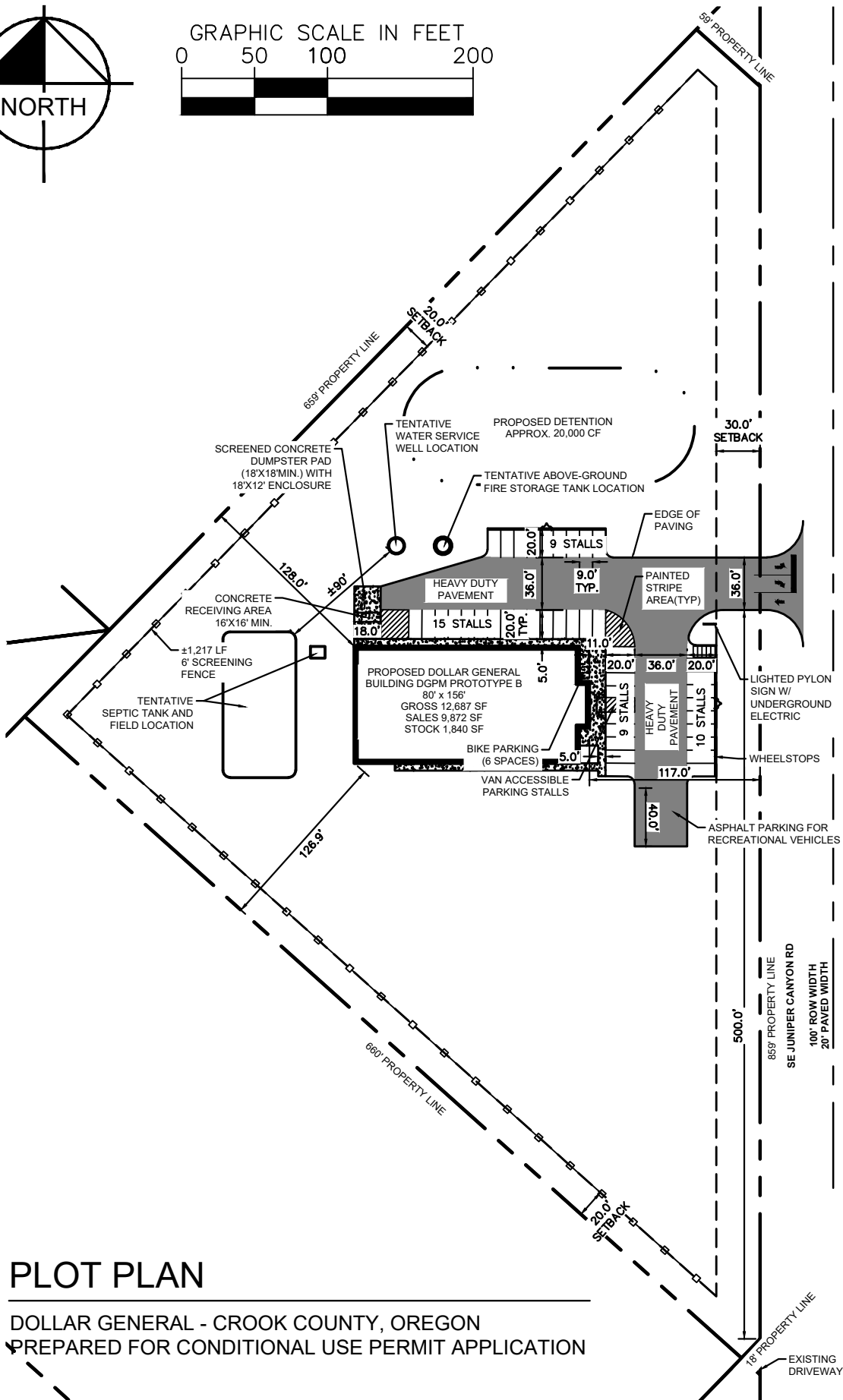
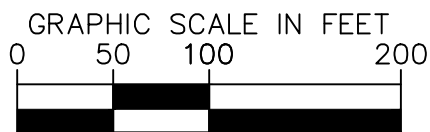
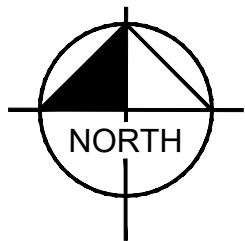

# PLOT PLAN

DOLLAR GENERAL - CROOK COUNTY, OREGON  
PREPARED FOR CONDITIONAL USE PERMIT APPLICATION

Date: January 08, 2024 - 8:33am / User: Liz.Willmot  
Path: K:\SEA\_Civil\SEA\_DS\090121 - Dollar General\090121 - Test\_Fix\GUP Plot Plan.dwg / Xref: xBk.rFP



## CONDITIONAL USE NARRATIVE STATEMENT

**APPLICANT:** Liz Willmot  
Kimley-Horn and Associates  
1201 Third Avenue, Suite 2800  
Seattle, WA 98101

**OWNER:** Julie and Ariana Mayers  
1308 NE Carson Street  
Prineville, OR 97754

**TRAFFIC ENGINEER:** Brad Lincoln  
Kimley-Horn and Associates  
2828 Colby Avenue, Suite 200  
Everett, WA 98201

### REQUEST:

This applicant is requesting a Conditional Use Permit for a proposed Dollar General store at 9660 SE Juniper Canyon Road, Prineville, Crook County, Oregon (APN 1616020000900).

### PROJECT DESCRIPTION

Situated 7.2 miles south of Prineville off SE Juniper Canyon Road, the 5.22-acre site will be a Dollar General. It will provide affordable grocery and general goods items for nearby residents. Centrally located between Ochoco Reservoir, Prineville Reservoir, and multiple other outdoor recreational activities, this Dollar General is conveniently located to serve as an amenity to the local population as well as transients commuting between these recreations. Dollar General's products cater to the community both in rural and populated areas by providing reasonably priced goods for all.



Figure 1: Project Location



## CROOK COUNTY CODE, TITLE 18

The subject site is zoned Residential Recreational Mobile Zone (RRM5). This zone is defined in the Crook County Code (CCC) §18.40.

### APPLICABLE CRITERIA:

Title 18, Crook County Zoning Code

- 18.40.020 Conditional Uses Permitted
- 18.40.040 Yard and Setback Requirements
- 18.40.050 Dimensional Standards
- 18.40.060 Signs
- 18.40.080 Site Plan Review
- 18.40.090 Lot Size
- 18.40.100 Limitations on Conditional Uses
- 18.40.110 Wildlife Policy Applicability
- 18.124.010 Access – Minimum Lot Frontage
- 18.124.020 Establishment of Clear-Vision Areas
- 18.124.030 Measurement of Clear-Vision Areas
- 18.124.070 Projections from Buildings
- 18.128.010 Off-Street Parking Requirements
- 18.128.015 Bicycle Parking
- 18.128.020 Off-Street Parking and Loading
- 18.128.030 Design and Improvement Standards for Parking Lots
- 18.160.010 Authorization to Grant or Deny Conditional Uses
- 18.160.020 General Criteria
- 18.160.030 General Conditions
- 18.160.040 Permit and Improvements Assurance
- 18.160.050 Standards Governing Conditional Uses
- 18.160.060 Procedure for Taking Action on Conditional Use Application.
- 18.160.070 Permit Expiration Dates.
- 18.160.080 Occupancy Permit
- 18.176.010 Access Management Standards
- 12.16.010 Permits Required (Street/Right-of-Way Use and Utility Permits)

**18.40.020 - Conditional Uses Permitted**

*In an RR(M)-5 zone, the following uses and their accessory uses are permitted when authorized in accordance with the requirements set forth by this section and Chapter 18.160 CCC.*

18.40.020(6)

*(6) Commercial activity directly related to recreation, including but not limited to motel, food and beverage establishment, recreation vehicle gasoline service station, recreation vehicle rental and storage facility and gift or sporting goods store.*

**APPLICANT RESPONSE:** CCC §18.40.020(6) states that, within the RRM5 zone, “Commercial activity directly related to recreation, including but not limited to motel, food and beverage establishment, recreation vehicle gasoline service station, recreation vehicle rental and storage facility and gift or sporting goods store” can be a permitted conditional use. This applicant is requesting a Conditional Use Permit to permit a Dollar General store on the subject property as described in the project description.

It will provide affordable grocery and general goods items for nearby residents. Centrally located between Ochoco Reservoir, Prineville Reservoir, and multiple other outdoor recreational activities, this Dollar General is conveniently located to serve as an amenity to the local population as well as transients commuting between these recreations.

**18.40.040 - Yard and Setback Requirements**

*In an RR(M)-5 zone, the following yard and setbacks shall be maintained:*

*(1) The front setback shall be a minimum of 20 feet from a property line fronting on a local minor collector or marginal access street ROW, 30 feet from a property line fronting of a major collector ROW, and 80 feet from an arterial ROW unless other provisions from combining accesses are provided and approved by the county.*

*(2) There shall be a minimum side yard of 10 feet for all uses, except in the case of a nonresidential use adjacent to a residential use the minimum side yard shall be 20 feet.*

*(3) The minimum rear yard shall be 20 feet.*

**APPLICANT RESPONSE:** The proposed development is meeting the required setbacks in the following manner:

	<i>Crook County Code Requirement</i>	<i><u>Proposed Building Setback</u></i>
<i>Front Building Setback (from Major Collector)</i>	30'	117'
<i>Rear Yard</i>	20'	126' (southwest) 128' (northwest)
<i>Side Yard (residential adjacent)</i>	20'	126' (southwest) 128' (northwest)

The proposed development will meet all Crook County yard and setback requirements.

**18.40.050 - Dimensional Standards**

*18.40.050 Dimensional standards.*

*In an RR(M)-5 zone, the following dimensional standards shall apply:*

*(1) Percent of Lot Coverage. The main building and accessory buildings located on any building site or lot shall not cover in excess of 30 percent of the total lot area.*

*(2) Building Height. No building or structure, nor the enlargement of any building or structure, shall be hereafter erected to exceed two stories or more than 30 feet in height.*

**APPLICANT RESPONSE:** The proposed development is meeting the required setbacks in the following manner:

	<i>Crook County Code Requirement</i>	<i>Proposed in CUP Plot Plan</i>
<i>Percent of Lot Coverage by Building</i>	30%	6%
<i>Maximum Building Height</i>	Two stories or 30'	21'

The proposed development will meet all Crook County dimensional standards.

**18.40.060 – Signs**

*In an RR(M)-5 zone, the following signs are permitted:*

*(1) Business signs provided the aggregate of the signs do not exceed an area equal to one square foot of sign face for each foot of lot frontage or 100 square feet of sign face, whichever is the least, and the sign is not in or extending over a street ROW.*

*(2) The specific types, sizes, design and number of permitted commercial signs shall conform to the general provisions governing signs found in CCC 18.124.040.*

**APPLICANT RESPONSE:** The proposed pylon sign has an area of 50 SF per side, totaling 100 SF for the frontage of SE Juniper Avenue. The proposed sign location is behind the 30-foot building setback and is not proposed to extend over the SE Juniper Canyon Road ROW.

The applicant will apply for a sign permit as part of the building permit review.

**18.40.080 – Site Plan Review**

*In an RR(M)-5 zone, an outright use except for single-family dwellings and farm use permitted shall be subject to the provisions of this section. Before a new building may be constructed or an existing building enlarged or substantially altered, a site development plan shall be submitted to the planning director for approval. Construction and development of the site plan shall be in conformance with plans approved by the planning director. In considering a site plan for a proposed use in an RR(M)-5 zone, the planning director shall take into account the impact of the proposed use on nearby residential and commercial property, on the capacity of the street to carry traffic and serve its function and on the appearance from or along a street. The planning director may require as a condition of approval:*

- (1) An increase in the required yards.*
- (2) Additional off-street parking.*
- (3) Screening of the proposed use by a fence or landscaping.*
- (4) Limitations on signs or lighting.*
- (5) Limitations on the number, size and location of ingress, egress and other point of access.*
- (6) Any other conditions considered necessary to achieve the purpose of this title.*

**APPLICANT RESPONSE:** The applicant will submit for a Site Plan Review prior to the start of construction. The applicant understands that the Conditional Use Permit which is currently being applied for is not a Site Plan Review, and an additional review with detailed construction documents will be required prior to construction permit issuance. With regard to the items above – please see the responses below:

- (1) An increase in the required yards.* - the amount of buffer between the property lines and the nearest structures are adequate and there would be no need for increased required yards.
- (2) Additional off-street parking.* – the tenant has determined that the 41 parking spaces plus space for oversized vehicles is more than sufficient for their use.
- (3) Screening of the proposed use by a fence or landscaping.* – there will be a 6’ high wooden privacy fence on the rear two property lines to screen from neighboring properties.

*(4) Limitations on signs or lighting.* – the parking lot lighting will be limited to the parking lot areas for safety only. Tenant does request that these stay on during the evening hours for security. Wall packs will be on the building. A photometric plan will be submitted with our land development drawings showing foot candles at the property lines. Code will be met.

*(5) Limitations on the number, size and location of ingress, egress and other point of access.* – we are proposing only one driveway and we are spacing it appropriately from other driveways in the nearby vicinity. See TIA for more detail.

**18.40.090 – Lot Size**

*In an RR(M)-5 zone, the following lot size shall apply:*

*The minimum property size for a new parcel shall be five acres in size.*

**APPLICANT RESPONSE:** The existing property is approximately 5.22 acres per the Crook County Property Information. The proposed development does not propose new parcels and the existing 5.22-acre property will remain.

**18.40.100 – Limitations on Conditional Uses**

*In addition to the standards and conditions that may be attached to the approval of conditional uses as provided by Chapter 18.160 CCC, the following limitations shall apply to conditional uses in an RR(M)-5 zone:*

*(1) An application for a conditional use in the RR(M)-5 zone may be denied if, in the opinion of the planning commission, the proposed use is not related to or sufficiently dependent upon the recreational resource of the area.*

*(2) An application for a conditional use in the RR(M)-5 zone may be denied if the applicant fails to demonstrate that a location in close proximity to the recreation resource to be served is essential to the public interest and to the full development of the recreation resource.*

*(3) In approving a conditional use in the RR(M)-5 zone, the commission shall be satisfied that the applicant is fully apprised of the county's policy relative to development or maintenance of access improvements to recreation-residential areas, and may attach the following as a condition of approval: The granting of this permit in no way obligates Crook County to the provision, development or maintenance of access, required or otherwise to the property for which this permit is issued.*

*(4) The planning commission may require establishment and maintenance of fire breaks, the use of fire-resistant materials in construction and landscaping or may attach other similar conditions or limitations that will serve to reduce fire hazards or prevent the spread of fire to surrounding areas.*

*(5) The planning commission may limit changes in the natural grade of land, or the alteration, removal or destruction of natural vegetation in order to prevent or minimize erosion or pollution.*

*(6) Compliance with the comprehensive plan shall be required for the approval of any application for a conditional use in the RR(M)-5 zone.*

*(7) An application for a commercial use, subdivision or PUD may be denied if the subject proposal does not have immediate or adequate access to an existing or planned designated arterial or collector street.*

**APPLICANT RESPONSE:** The applicant understands that the County reserves the right to deny the Conditional Use Permit if they determine that the project does not meet the approval criteria.

1. The applicant argues that the proposed retail store supports recreational use by offering affordable grocery and general goods items for users of nearby recreational areas. Asphalt parking for recreational vehicles is offered onsite, allowing users to stop on the way to/from their recreation for supplies.
2. The site is located on SE Juniper Canyon Road, which is the main thoroughfare between Prineville and the Prineville Reservoir State Park. State Route 26 passes through Prineville, so any hikers/fishers/boaters looking to visit Prineville Reservoir State Park that live to the north will pass along the site as they travel south via SE Juniper Canyon Road. The proposed general goods store offers recreational users the opportunity to stock up on last-minute items and groceries before or after their activities.
3. The applicant has proposed a single access to the site and intends to fully maintain it to ensure its use for all customers and recreational users.
4. The proposed site plan includes an above-ground water tank for the purposes of fire protection. The applicant would follow the requirements from the County regarding other fire suppression measures.
5. The proposed development will minimize earthwork disturbance to the greatest extent feasible. It is the intention of the design team to leave the site areas south of the building/parking and north of the detention pond in its natural state.
6. Based on the applicant's research, the only applicability of the comprehensive plan to this site is the recreational use, which is the purpose of this Conditional Use Permit.
7. The project proposes a single access point to an existing street.

#### **18.40.110 – Wildlife Policy Applicability**

*The residential density limitations and the lot and parcel size limitations found in Wildlife Policy 2 of the Crook County comprehensive plan do not apply to any nonresource zones.*

**APPLICANT RESPONSE:** The Wildlife Policy 2 in the Crook County Comprehensive Plan states “Density with a Crucial Wintering Area for deer shall not be greater than one residence per 160 acres and for the General Winter Range not more than one residence per 80 acres.” The proposed development is not residential; therefore, this section does not apply.

**18.124.010 – Access – Minimum Lot Frontage**

*Every lot shall abut a street, other than an alley, for at least 50 feet. (Ord. 280 § 15 (Exh. O), 2015; Ord. 18 § 4.010, 2003)*

**APPLICANT RESPONSE:** The proposed development abuts SE Juniper Canyon Road for 859-feet. This meets the CCC §18.124.010 requirement of a minimum of 50-feet.



**18.124.020 – Establishment of Clear-Vision Areas**

*In all zones, a clear-vision area shall be maintained on the corners of all property at the intersection of two streets or a street and a railroad. A clear-vision area shall contain no planting, fence, wall, structure or temporary or permanent obstruction exceeding two and one-half feet in height, measured from the top of the curb, or where no curb exists, from the established street center line grade, except that trees exceeding this height may be located in this area, provided all branches and foliage are removed to a height of eight feet above the grade. (Ord. 280 § 15 (Exh. O), 2015; Ord. 18 § 4.020, 2003)*

**APPLICANT RESPONSE:** The property is not located at the intersection of two streets, therefore the clear vision area is not applicable.

**18.124.030 – Measurement of Clear-Vision Areas**

*A clear-vision area shall consist of a triangular area two sides of which are lot lines measured from the corner intersection of the street lot lines for a distance specified in this regulation, or, where the lot lines have rounded corners, the lot lines extended in a straight line to a point of intersection and so measured, and the third side of which is a line across the corner of the lot joining the nonintersecting ends of the other two sides. The following measurements shall establish clear-vision areas within the county:*

- (1) In an agricultural, forestry or industrial zone, the minimum distance shall be 30 feet, or at intersections including an alley, 10 feet.*
- (2) In all other zones, the minimum distance shall be in relationship to street and road right-of-way widths as follows:*

<b>Row Width</b>	<b>Clear-Vision Measurement</b>
<i>80 feet and more</i>	<i>20 feet</i>
<i>60 feet</i>	<i>30 feet</i>
<i>50 feet</i>	<i>40 feet</i>

**APPLICANT RESPONSE:** The property is not located at the intersection of two streets, therefore the clear vision area is not applicable.

**18.124.070 – Projections from Buildings**

*Architectural features such as cornices, eaves, canopies, sunshades, gutters, chimneys and flues shall not project more than three feet into a required yard; provided, that the projection is not closer than three feet to a property line.*

**APPLICANT RESPONSE:** Code section 18.124.070 does not apply. The building proposed has no architectural features projecting into the front or side yards.

**18.128.010 – Off-Street Parking Requirements**

*At the time of construction, reconstruction or enlargement of a structure or at the time a use is changed in any zone, off-street parking space shall be provided as follows unless greater requirements are otherwise established. Where square feet of the structure or use are specified as the basis for the requirement, the area measured shall be the gross floor area primary to the functioning of the particular use of the property. When the requirements are based on the number of employees, the number counted shall be those working on the premises during the largest shift at peak season. Fractional space requirements shall be counted as a whole space.*

*6. Commercial*

*a. Retail store except as provided in subsection (6)(b) of this section.*

*One space per 300 square feet of floor area designated for retail sales.*

**APPLICANT RESPONSE:** Per CCC §18.040.070 and §18.128.010, the proposed development is required to provide 1 vehicle parking space per 300 SF of building area. For a total building area of 12,687, 43 spaces are required, and 43 spaces are provided.

**18.128.015 – Bicycle Parking**

*(1) Applicability. Excluding uses listed in subsection (2) of this section, all proposed development where required new vehicle parking areas number 10 or more spaces must include a designated area for bicycle parking.*

*(2) Exemptions. This section does not apply to single-family and duplex housing, home occupations, and agricultural uses. The county roadmaster may exempt other uses upon finding that, due to the nature of the use or its location, it is unlikely to have any attendees, patrons or employees arriving by bicycle.*

*(3) Standards. The minimum number of required bicycle parking spaces shall be:*

*(a) For all uses subject to this section, two bicycle spaces for the first 10 motorized vehicle parking areas, plus one additional bicycle space for each additional 10 motorized vehicle parking spaces thereafter.*

*(4) Design. Unless otherwise identified in subsection (3) of this section, bicycle parking shall consist of staple-design steel racks or other county-approved racks, lockers, or storage bins providing a safe and secure means of storing a bicycle.*

*(5) Location. For institutional, employment, and commercial uses, the designated area for bicycle parking shall be within 50 feet of a public entrance.*

*(6) Hazards. Bicycle parking shall not impede or create a hazard to pedestrians or vehicles, and shall be located so as to not conflict with the vision clearance standards of this code.*

**APPLICANT RESPONSE:** Per CCC §18.128.015, two bicycle parking spaces are required for the first 10 vehicle spaces, and 1 space for each additional 10 vehicle spaces. A total of 6 bicycle spaces are required for the proposed 43 vehicle spaces, and 6 bicycle spaces are proposed.

**18.128.020 – Off-Street Parking Requirements**

*Buildings or structures to be built or substantially altered which receive and distribute materials and merchandise by trucks shall provide and maintain off-street loading berths in sufficient number and size to handle adequately the needs of the particular use. Off-street parking areas used to fulfill the requirements of this title shall not be used for loading and unloading operations except during periods of the day when not required to care for parking needs. General provisions are as follows:*

*(1) The provisions and maintenance of off-street parking and loading spaces is a continuing obligation of the property owner. Should the owner or occupant of any lot or building change the use to which the lot or building is put, thereby increasing off-street parking or loading requirements, it shall be a violation of this title to begin or maintain such altered use until such time as the increased off-street parking or loading requirements are complied with.*

*(2) Requirements for types of buildings and uses not specifically listed in this title shall be determined by the planning commission based upon the requirements for comparable use listed.*

*(3) In the event several uses occupy a single structure or parcel of land, the total requirements for off-street parking shall be the sum of the requirements of the several uses computed separately.*

*(4) Owners of two or more uses or parcels of land may agree to utilize jointly the same parking and loading spaces when the hours of operation do not overlap; provided, that satisfactory legal evidence is presented to the county in the form of deeds, leases or contracts to establish the joint use.*

*(5) Off-street parking spaces for dwellings shall be located on the same parcel with the dwelling. Other required parking spaces for residential uses shall be located not farther than 500 feet from the building or use they are required to serve, measured in a straight line from the building.*

*(6) Required parking spaces shall be available for the parking of passenger automobiles of residents, customers, patrons and employees only and shall not be used for storage of vehicles or materials or for the parking of trucks used in conducting the business or use.*

**APPLICANT RESPONSE:** An asphalt parking area having dimensions of 36' x 40' is proposed on the south side of the parking lot for the use of recreational vehicles such as RVs, campers, boats, etc.

**18.128.030 – Design and Improvement Standards for Parking Lot**

*(1) Areas used for parking for more than two vehicles shall have durable and dustless surfaces adequately maintained.*

*(2) Except for parking in connection with dwelling, parking and loading areas adjacent to or within a residential zone or adjacent to a dwelling shall be designed to minimize disturbance to residents by the erection between the uses of a sight-obscuring fence or planted screen of not less than six feet in height except where vision clearance is required.*

*(3) Parking spaces along the outer boundaries of a parking lot shall be contained by a bumper rail or by a curb which is at least four inches high and which is set back a minimum of one and one-half feet from the property line.*

*(4) Artificial lighting, which may be provided, shall not shine or create glare in any residential zone or on any adjacent dwelling.*

*(5) Access aisles shall be of sufficient width to permit easy turning and maneuvering.*

*(6) Except for single-family and duplex dwellings, groups of more than two parking spaces shall be so located and served by a driveway that their use will require no backing movements or other maneuvering within a street right-of-way other than an alley.*

*(7) Service drives to off-street parking areas shall be designed and constructed both to facilitate the flow of traffic and to provide maximum safety for vehicles and pedestrians. The number of service drives shall be limited to the minimum that will accommodate anticipated traffic.*

*(8) Driveways shall have a minimum vision clearance area framed by the intersection of the driveway center line, the street right-of-way line, and a straight line joining said lines through points 30 feet from their intersection.*

*(9) The standards set forth in the table that follows shall be the minimum for parking lots approved under this title (refer to table).*

**APPLICANT RESPONSE:** The proposed development will have heavy-duty pavement along the drive aisles to allow pavement to withstand larger vehicles and delivery trucks traversing the site and the parking stalls will be standard-duty pavement. The site proposes a fence at the west and south setback lines for minimal disturbance to the residential lots adjacent to the site. All parking stalls along the outer edge of the parking lot will have bumper rails or wheel stops per CCC §18.128.030(3). All proposed parking stalls are 20-feet long by 9-feet wide and meet the CCC §18.128.030(9) table requirements for 90-degree parking of 19-feet long by 8.5-feet wide.

**18.160.010 – Authorization to Grant or Deny Conditional Uses**

*A conditional use listed in this title shall be permitted, altered or denied in accordance with the standards and procedures of this title and this chapter by action of the planning director or planning commission. In the case of a use existing prior to the effective date of the ordinance codified in this title and classified in this title as a conditional use, a change in use or in lot area or an alteration of structure shall conform with the requirements for a conditional use. (Ord. 236 § 3 (Exh. C), 2010; Ord. 18 § 6.010, 2003)*

**APPLICANT RESPONSE:** The applicant requests that Crook County grant the proposed conditional use of a retail store in a recreational area on the grounds that it is supporting those utilizing local recreational facilities and is conveniently located on a major passageway to/from local recreational facilities. The use did not exist on the site prior to the effective date of the ordinance.

**18.160.020 – General Criteria**

*In judging whether or not a conditional use proposal shall be approved or denied, the planning director or planning commission shall weigh the proposal's appropriateness and desirability or the public convenience or necessity to be served against any adverse conditions that would result from authorizing the particular development at the location proposed and, to approve such use, shall find that the following criteria are either met, can be met by observance of conditions, or are not applicable:*

- (1) The proposal will be consistent with the comprehensive plan and the objectives of the zoning ordinance and other applicable policies and regulations of the county.*
- (2) Taking into account location, size, design and operation characteristics, the proposal will have minimal adverse impact on the (a) livability, (b) value and (c) appropriate development of abutting properties and the surrounding area compared to the impact of development that is permitted outright.*
- (3) The location and design of the site and structures for the proposal will be as attractive as the nature of the use and its setting warrant.*
- (4) The proposal will preserve assets of particular interest to the county.*
- (5) The applicant has a bona fide intent and capability to develop and use the land as proposed and has some appropriate purpose for submitting the proposal, and is not motivated solely by such purposes as the alteration of property values for speculative purposes.*

**APPLICANT RESPONSE:** The proposed project complies with the general criteria of this section in the following manner:

1. Based on the applicant's research, the only applicability of the comprehensive plan to this site is the recreational use, which is the purpose of this Conditional Use Permit.
2. The proposed improvements are situated in approximately the center of the triangular lot. It is the intention of the applicant to leave the southern and northern portions of the triangular lot undisturbed to both minimize earthwork disturbance and also provide adequate buffer from adjacent properties. A screening fence is proposed to run the entire length of the northwestern and southwestern property lines as an additional buffer between existing properties and the proposed use. The proposed use as a general store provides an additional amenity of affordable groceries to nearby residents. Based on the overall lot size relative to the proposed developments, ample setbacks, addition of a screening fence, and the offer of grocery use to residents, the property will not affect the livability, value, or appropriate development of abutting properties or the surrounding area.
3. The proposed building will comply with all Crook County requirements for appearance. The applicant will keep the building and property adequately maintained to ensure its continued appearance.

4. Given the size of the lot relative to the area of proposed improvements, there will be ample space on the northern and southern portions of the site that will be left undisturbed, which is consistent with adjacent developments that appear to have low density.
5. The applicant intends to develop and use the land as proposed.

**18.160.030 – General Conditions**

*In addition to the standards and conditions set forth in a specific zone, this chapter, and other applicable regulations, in permitting a new conditional use or the alteration of an existing conditional use, the planning director or planning commission may impose conditions which it finds necessary to avoid a detrimental impact and to otherwise protect the best interests of the surrounding area or the county as a whole. These conditions may include the following:*

- (1) Limiting the manner in which the use is conducted including restricting the time an activity may take place and restraints to minimize such environmental effects as noise, vibration, air pollution, glare and odor.*
- (2) Establishing a special yard or other open space or lot area or dimension.*
- (3) Limiting the height, size or location of a building or other structure.*
- (4) Designating the size, number, location and nature of vehicle access points.- as shown on site plan*
- (5) Increasing the amount of street dedication, roadway width or improvements within the street right-of-way.*
- (6) Designating the size, location, screening, drainage, surfacing or other improvement of a parking area or loading area.*
- (7) Limiting or otherwise designating the number, size, location, height and lighting of signs.*
- (8) Limiting the location and intensity of outdoor lighting and requiring its shielding.*
- (9) Requiring diking, screening, landscaping or another facility to protect adjacent or nearby property and designating standards for its installation and maintenance.*
- (10) Designating the size, height, location and materials for a fence.*



*(11) Protecting and preserving existing trees, vegetation, water resources, wildlife habitat or other significant natural resources.*

*(12) Other conditions necessary to permit the development of the county in conformity with the intent and purpose of this title and the policies of the comprehensive plan.*

**APPLICANT RESPONSE:** The applicant recognizes that the planning commission may impose additional requirements on the project as a condition of approval. At the time of submittal, the proposed development is compliant with all site layout criteria for this zone, and the only deviation from standard requirements that is requested is a retail use in a recreational zone, which is the purpose of this Conditional Use Permit. In addition, applicant responses are below to each item above:

*(1) Limiting the manner in which the use is conducted including restricting the time an activity may take place and restraints to minimize such environmental effects as noise, vibration, air pollution, glare and odor.* – understood. Typical Dollar General hours are established and change based on the market they serve. 8am to 10pm are typical hours to expect.

*(2) Establishing a special yard or other open space or lot area or dimension.* – there is plenty of open space on this lot to be sure we are considerate of those nearby.

*(3) Limiting the height, size or location of a building or other structure.* – this building will be 12,687 SF and one story. It is placed roughly in the middle of the parcel to leave plenty of open space around.

*(4) Designating the size, number, location and nature of vehicle access points.* - as shown on site plan, we have one access point that is in a location determined by the traffic engineers to be in the safest possible place.

*(5) Increasing the amount of street dedication, roadway width or improvements within the street right-of-way.* – our Traffic Study has revealed that the roadway does not need to be widened with the traffic expected.

*(6) Designating the size, location, screening, drainage, surfacing or other improvement of a parking area or loading area.* – the site plan shows the locations of all improvements. Please note these are subject to change slightly after grading, drainage and utility plans are done.

*(7) Limiting or otherwise designating the number, size, location, height and lighting of signs.* – permanent signage will be wall signage and a pole sign.

*(8) Limiting the location and intensity of outdoor lighting and requiring its shielding. – the parking lot lighting will be down lights and a photometric plan will be designed during permitting.*

*(9) Requiring diking, screening, landscaping or another facility to protect adjacent or nearby property and designating standards for its installation and maintenance. – a 6' high wooden fence will be along the rear property lines.*

*(10) Designating the size, height, location and materials for a fence. – 6' high wooden fence. See site plan for location along rear property lines.*

*(11) Protecting and preserving existing trees, vegetation, water resources, wildlife habitat or other significant natural resources. – the parcel does not include any of these features that we know of at this point.*

*(12) Other conditions necessary to permit the development of the county in conformity with the intent and purpose of this title and the policies of the comprehensive plan. - Understood.*

**18.160.040 – Permit and Improvements Assurance**

*The commission may require an applicant to furnish the county with an agreement and security in accordance with CCC [17.40.080](#) and [17.40.090](#) that the planning director or planning commission deems necessary to guarantee development in accordance with the standards established and the conditions attached in granting a conditional use permit.*

**APPLICANT RESPONSE:** The applicant understands that the commission may require an agreement with the county to guarantee development standards. If such an agreement is requested, the applicant would be amenable, pending a review of the conditions of the agreement.

**18.160.050 – Standards Governing Conditional Uses**

*A conditional use shall comply with the standards of the zones in which it is located and with the standards and conditions set forth in this section.*

*(10) Commercial Use or Accessory Use Not Wholly Enclosed Within a Building, Retail Establishment, Office, Service Commercial Establishment, Financial Institution or Personal or Business Service Establishment on a Lot Abutting or Across the Street from a Lot in a Residential Zone. In any zone, a commercial use or accessory use not wholly enclosed within a building or a*

*retail establishment, office, service commercial establishment, financial institution, or personal or business service establishment on a lot abutting or across the street from a lot in a residential zone may be permitted as a conditional use subject to the following standards:*

- (a) A sight-obscuring fence of evergreen hedge may be required by the planning director or planning commission when, in the director's or its judgment, such a fence or hedge or combination thereof is necessary to preserve the values of nearby properties or to protect the aesthetic character of the neighborhood or vicinity.*
- (b) In addition to the requirements of the applicable zone, the planning director or planning commission may further regulate the placement and design of signs and lights in order to preserve the values of nearby properties; to protect them from glare, noise or other distractions; or to protect the aesthetic character of the neighborhood or vicinity.*
- (c) In order to avoid unnecessary traffic congestion and hazards, the planning director or planning commission may limit access to the property.*

**APPLICANT RESPONSE:** The proposed project complies with the general criteria of this section in the following manner:

1. The proposed commercial use on the site will be wholly enclosed within the proposed building. However, as an additional measure to protect the aesthetic character of the neighborhood and adjacent properties, a screening fence is proposed along the entirety of the northwestern and southwestern property lines, which abut a residential use.
2. The proposed location of the lighted pylon sign is shown on the Plot Plan for review by the commission. It is understood that the commission may require a relocation of this sign; the applicant may be able to accommodate this, pending review of the suggested relocation.
3. It is understood that the commission may limit access to the property. Based on the traffic impact analysis submitted with this package, it is the determination of the applicant's traffic engineer that a restricted access is not warranted based on the development's proposed trips and the existing traffic on SE Juniper Canyon Road. The applicant would request the commission's review of their findings for confirmation of this determination.

#### **18.160.060 – Procedure for Taking Action on Conditional Use Application**

*Permit expiration dates and permit extensions for conditional uses are as stated in CCC 18.172.060.*

**APPLICANT RESPONSE:** Per CCC §18.172.060(2)(b) states “A land use approval is void two years after the date the decision becomes final if the use approved in the permit is not initiated within that time period.” Per CCC §18.172.060(2)(d) “the director shall grant up to four two-year extensions to a land use approval regardless of whether the applicable criteria have changed.” This is understood by the applicant and will be utilized if necessary.

**18.160.070 – Permit Expiration Dates**

*Permit expiration dates and permit extensions for conditional uses are as stated in CCC 18.172.060.*

**APPLICANT RESPONSE:** Per CCC 18.172.060(2)(b) states “A land use approval is void two years after the date the decision becomes final if the use approved in the permit is not initiated within that time period.” Per CCC 18.172.060(2)(d) “the director shall grant up to four two-year extensions to a land use approval regardless of whether the applicable criteria have changed.” This is understood by the applicant and will be utilized if necessary.

**18.160.080 – Occupancy Permit**

*The planning director or planning commission may require an occupancy permit for any conditional use permitted and approved pursuant to the provisions of this title. The planning director or planning commission shall consider such a requirement for any use authorized by a conditional use permit for which this title requires on-site or off-site improvements or where such conditions have been established by the planning director or planning commission upon approval of such use. The requirement of an occupancy permit shall be for the purpose of ensuring permit compliance and an occupancy permit shall not be issued except as set forth by the planning director or planning commission. The authority to issue an occupancy permit upon compliance with the requirements and conditions of a conditional use permit may be delegated by the planning director or planning commission at the time of approval of a specific conditional use permit to the planning director and/or the building official.*

**APPLICANT RESPONSE:** It is understood that the proposed development will require an occupancy permit following the completion of construction and prior to operation as the proposed use. The applicant will comply with this requirement.

**18.176.010 – Access Management Standards**

*(1) Purpose and Intent. This section implements the street access policies of the Crook County transportation system plan. It is intended to promote safe vehicle access and egress to properties, while maintaining traffic operations in conformance with adopted standards. “Safety,” for the purposes of this chapter, extends to all modes of transportation.*

*(2) Traffic Impact Analysis Requirements. The county, in reviewing a development proposal or other action requiring an approach permit, may require a traffic impact analysis, pursuant to subsection (3) of this section, to determine compliance with this code.*

*(3) Approach and Driveway Development Standards. Approaches and driveways shall conform to all the following development standards:*

*(a) The number of approaches on higher classification streets (e.g., collector and arterial streets) shall be minimized; where practicable, access shall be taken first from a lower classification street.*

*(b) Approaches shall conform to the spacing standards of subsections (4) and (5) of this section, and shall conform to minimum sight distance and channelization standards of the roadway authority.*

*(c) The county roadmaster may limit the number or location of connections to a street, or limit directional travel at an approach to one-way, right-turn only, or other restrictions, where the roadway authority determines that mitigation is required to alleviate safety or traffic operations concerns.*

*(d) Where the spacing standards of the roadway authority limit the number or location of connections to a street or highway, the county roadmaster may require a driveway extend to one or more edges of a parcel and be designed to allow for future extension and inter-parcel circulation as adjacent properties develop. The county roadmaster may also require the owner(s) of the subject site to record an access easement for future joint use of the approach and driveway as the adjacent property(ies) develop(s).*

*(e) Where applicable codes require emergency vehicle access, approaches and driveways shall be designed and constructed to accommodate emergency vehicle apparatus and shall conform to applicable fire protection requirements. The county roadmaster may restrict parking, require signage, or require other public safety improvements pursuant to the recommendations of an emergency service provider.*

*(f) As applicable, approaches and driveways shall be designed and constructed to accommodate truck/trailer-turning movements.*

*(g) Where an accessible route is required pursuant to Americans with Disabilities Act (ADA), approaches and driveways shall meet accessibility requirements where they coincide with an accessible route.*

*(h) The county roadmaster may require changes to the proposed configuration and design of an approach, including the number of drive aisles or lanes, surfacing, traffic-calming features, allowable turning movements, and other changes or mitigation, to ensure traffic safety and operations.*

*(i) Where a new approach onto a state highway or a change of use adjacent to a state highway requires ODOT approval, the applicant is responsible for obtaining ODOT approval.*

*(j) Where an approach or driveway crosses a drainage ditch, canal, railroad, or other feature that is under the jurisdiction of another agency, the applicant is responsible for obtaining all required approvals and permits from that agency prior to commencing development.*

*(k) Where a proposed driveway crosses a culvert or drainage ditch, county roadmaster may require the developer to install a culvert extending under and beyond the edges of the driveway on both sides of it, pursuant to applicable public works/engineering design standards.*

*(l) Except as otherwise required by the applicable roadway authority or waived by the county roadmaster, temporary driveways providing access to a construction site or staging area shall be paved or graveled to prevent tracking of mud onto adjacent paved streets.*

*(4) Approach Separation from Street Intersections. Except as provided by subsection (6) of this section, the following minimum distances shall be maintained between approaches and street intersections, where distance is measured from the edge of an approach surface to the edge of the roadway at its ultimate designated width:*

*(a) On an arterial street: one mile, except as required by ODOT, pursuant to Oregon Administrative Rule (OAR) 734-051, for state highways.*

*(b) On a major collector street: one-half mile.*

*(c) On a minor collector street: one-quarter mile.*

*(d) On a local street: 150 feet.*

*(5) Approach Spacing. Except as provided by subsection (6) of this section or as required to maintain street operations and safety, the following minimum distances shall be maintained between approaches, where distance is measured from the edge of one approach to the edge of another:*

*(a) On an arterial street: 1,200 feet based on speed limit or posted speed, as applicable, except as otherwise required by ODOT for a state highway, pursuant to Oregon Administrative Rules (OAR) 734-051.*

*(b) On a major collector street: 500 feet.*

*(c) On a minor collector street: 300 feet.*

*(d) On a local road: access to each lot permitted.*

*(6) Exceptions and Adjustments. The county roadmaster may approve adjustments to the spacing standards in subsections (4) and (5) of this section, where an existing connection to a county road does not meet the standards of the roadway authority and the proposed development moves in the direction of code compliance. The county roadmaster may also approve a deviation to the spacing standards on county roads where it can be demonstrated that mitigation measures, such as consolidated access (removal of one access), joint use driveways (more than one property uses same access), directional limitations (e.g., one-way), turning restrictions (e.g., right-in/right-out only), or other mitigation alleviate all traffic operations and safety concerns.*

*(7) Joint Use Access Easement and Maintenance Agreement. Where the county approves a joint use driveway, the property owners shall record an easement with the deed allowing joint use of and cross access between adjacent properties. The owners of the properties agreeing to joint use of the driveway shall record a joint maintenance agreement with the deed, defining maintenance responsibilities of property owners. The applicant shall provide a fully executed copy of the agreement to the county for its records, but the county is not responsible for maintaining the driveway or resolving any dispute between property owners.*

**APPLICANT RESPONSE:** The proposed project complies with the general criteria of this section in the following manner:

1. It is the intention of the applicant to provide safe vehicular access to and from the property to the maximum extent possible.
2. A traffic impact analysis has been provided as part of the Conditional Use Permit application package.
3. The proposed project complies with the general criteria of this section in the following manner:
  - a. The number of approaches on SE Juniper Canyon Road has been minimized and only one access point is proposed.
  - b. Subsections 4 and 5 have been addressed below. The proposed site access conforms with the minimum sight distance and channelization standards of Crook County.
  - c. It is understood that the County Roadmaster may limit access to the property. Based on the traffic impact analysis submitted with this package, it is the determination of the applicant's traffic engineer that a restricted access is not warranted based on the development's proposed trips and the existing traffic on SE Juniper Canyon Road. The applicant would request the Roadmaster's review of their findings for confirmation of this determination.
  - d. Based on preliminary traffic scoping conversations with the County, providing an opportunity for future cross-access opportunities is not anticipated to be required by the County Roadmaster.
  - e. The driveway has been designed to accommodate adequate access for emergency vehicle access.



- f. The driveway has been designed to accommodate adequate access for the delivery truck/trailer turning movements. The turning movements have been confirmed by the future end user for compliance with their design vehicle requirements.
  - g. Currently, no accessible sidewalks exist along SE Juniper Canyon Road, so accessible access across the proposed driveway and from the site to the right-of-way is not anticipated.
  - h. It is understood that the County Roadmaster may limit access to the property. Based on the traffic impact analysis submitted with this package, it is the determination of the applicant's traffic engineer that a restricted access is not warranted based on the development's proposed trips and the existing traffic on SE Juniper Canyon Road. The applicant would request the Roadmaster's review of their findings for confirmation of this determination.
  - i. The project is not proposing access to a state highway, so ODOT approval is not anticipated to be required.
  - j. The topographic survey that was performed of the site shows evidence of a roadside ditch along SE Juniper Canyon Road. The applicant will provide a new culvert across the driveway access to maintain functionality of the existing ditch per applicable public works/engineering design standards and secure approvals of the design prior to commencing development.
  - k. The topographic survey that was performed of the site shows evidence of a roadside ditch along SE Juniper Canyon Road. The applicant will provide a new culvert across the driveway access to maintain functionality of the existing ditch per applicable public works/engineering design standards.
  - l. A gravel temporary construction entrance will be provided to limit tracking of mud during construction activities.
4. Per §18.176.010(4)(b), the approach separation from major collector intersections shall be one-half mile and The proposed development property only has street access to SE Juniper Canyon Road with approximately 859-feet abutting the road. Since one-half mile is 2,640-feet and the site street facing property line is only 859-feet long, the proposed development will not be able to meet this requirement.
  5. Per §18.176.010(5)(b), driveway approaches must be 500-feet apart. The proposed development driveway proposes to meet the 500-foot driveway approach separation from the driveways to the southeast. This dimension is labeled on the CUP Plot Plan.
  6. The proposed development requests an exception to §18.176.010(4)(b). This exception will be addressed and analyzed in a Traffic Impact Analysis in accordance with CCC §18.180 to be submitted to Crook County for review.
  7. A joint-use driveway is not proposed with this project.

**12.16.010 – Permits Required (Street/Right-of-Way Use and Utility Permits)**

*(1) Activities Requiring a Permit. Placement of facilities and development within the right-of-way of a county road, and alteration of such facilities and development, shall be authorized only through facility permits issued by the Crook County road master in accordance with this chapter and other legislation. Facilities and development includes, but is not limited to, road improvements, sidewalks, new and reconstructed driveway or road approach intersections, utility placements, excavation, clearing, grading, culvert placement or replacement, storm water facilities, or any other facility, thing or appurtenance to be located within the county road right-of-way.*

*(2) Prohibited Activities. Landscaping and trees, landscaped timbers, rocks, irrigation facilities, walls, gates, fencing, nonstandard mailbox supports, stairways, and any other object or barrier that has the potential of hindering the normal operation, maintenance, or use of a public road or a county road shall generally be prohibited and subject to county enforcement as described herein.*

**APPLICANT RESPONSE:** The proposed development proposed the development of a driveway within the SE Juniper Canyon Road ROW. A Street/Right-of-Way Use and Utility Permit will be applied for prior to construction with the submission of plans and specifications of the work to be completed in the ROW.

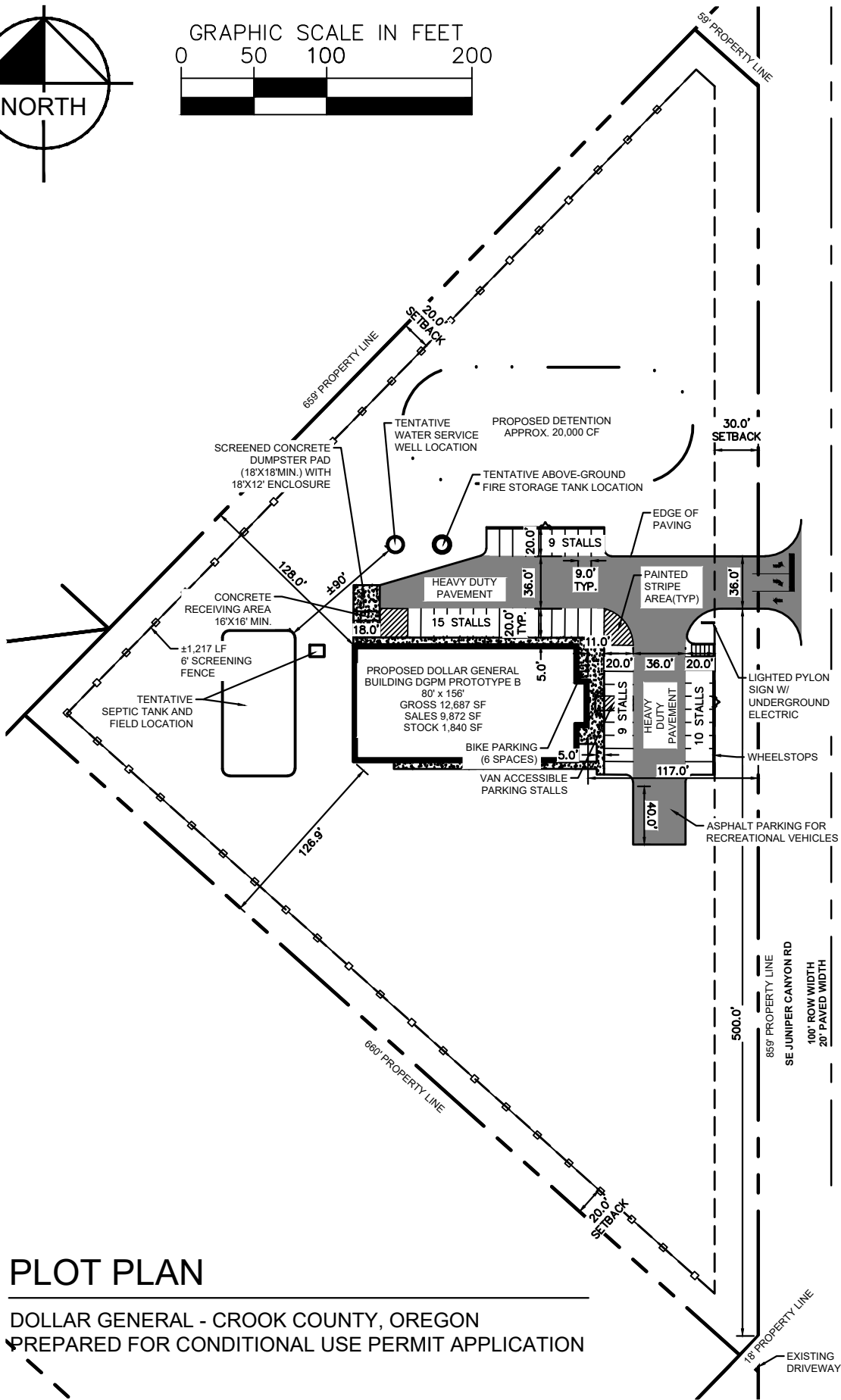
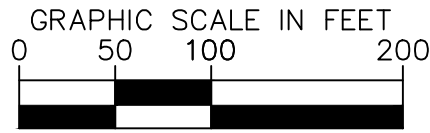
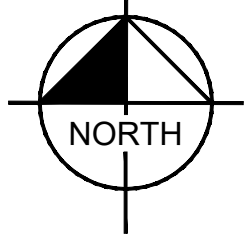

# PLOT PLAN

DOLLAR GENERAL - CROOK COUNTY, OREGON  
PREPARED FOR CONDITIONAL USE PERMIT APPLICATION

Date: January 08, 2024 - 8:33am / User: Liz.Willmot  
Path: K:\SEA\_Civil\SEA\_DS\080121 - Dollar General\090121001 - DG Prineville, OR\CAD\Exhibits\2024.01.08 - Test\_Fix\GUP Plot Plan.dwg / Xref: xBk.rFP

DESIGNER NOTE:  
IF ADDITIONAL SCREENING IS REQUIRED FOR ROOF MOUNTED EQUIPMENT PER LOCAL CODE, CONTACT DOLLAR GENERAL FOR APPROVAL.

DESIGNER NOTE:  
IF JURISDICTION REQUIRES ANY DEVIATIONS FROM PROTOTYPE IN DESIGN OR SIGNAGE, ELEVATIONS MUST BE SUBMITTED TO DOLLAR GENERAL FOR APPROVAL PRIOR TO SUBMISSION TO CITY.

**EXTERIOR FINISHES**

EXTERIOR FINISHES	STANDARD COLORS					
	MATCH SHERWIN WILLIAMS "FLM BEIGE"	PAINT OR SHERWIN WILLIAMS "MAYAN STONE"	BLACK	BRONZE	LOCAL COTTON WHITE	GALVALUME
EXTERIOR FINISHES ARE TO MATCH OR BE EQUAL TO COLORS SHOWN UNLESS AUTHORITY HAVING JURISDICTION DOES NOT ALLOW						
GUTTERS	•					
DOWN SPOUTS	•					
ENTRANCE PANELS METAL WALL PANELS, REVERSE-RIB PROFILE				•		
FRONT PANELS METAL WALL PANELS, REVERSE-RIB PROFILE						
SIDE AND REAR METAL WALL PANELS	•					
BRICK AT BUILDING BASE		•				
AWNINGS					•	
COPING AND ROOF TRIM					•	
STOREFRONT SYSTEM					•	
STANDING SEAM METAL ROOF PANELS						•
LINER PANELS, 28 GA (INTERIOR SALES FLOOR & RECEIVING AREA)					•	

NOTE:  
1. REFER TO SHEET T01 FOR ADDITIONAL INFORMATION ON RECOMMENDED NATIONAL ACCOUNT VENDORS.  
2. NATIONAL ACCOUNT AND CONTACT INFORMATION SUBJECT TO CHANGE.

**ELEVATION KEYED NOTES**

- 1 SIGN FURNISHED AND INSTALLED BY DOLLAR GENERAL CORP. WITH CIRCUIT AS NOTED ON ELECTRICAL PLAN. SIGN TO BE CENTERED ON FRONT OF BUILDING. CONTRACTOR IS TO PROVIDE ADEQUATE BLOCKING AS REQUIRED BY SIGN MANUFACTURER TO SUPPORT SIGN WEIGHT OF UP TO 1,400 LBS. EXTERIOR CANOPY SIGN SHALL BE SUPPORTED BY THE FACE OF CANOPY. CONTRACTOR IS TO PROVIDE ADEQUATE STRUCTURE TO SUPPORT SIGN. COORDINATE THE PROPER SIGNAGE TO BE USED WITH DOLLAR GENERAL.
- 2 NOT USED.
- 3 NOT USED.
- 4 NOT USED.
- 5 WALL PACK 12'-0" TO J-BOX. REFER TO ELEC. DRAWINGS FOR ADDITIONAL INFO.
- 6 NOT USED.
- 7 TRIM OVER METAL PANELS - SEE EXTERIOR FINISH SCHEDULE FOR COLOR.
- 7A FLASHING OVER BRICK - MATCH COLOR OF ADJACENT METAL PANELS.
- 8 GUTTER AND DOWNSPOUT - SEE EXTERIOR FINISH SCHEDULE FOR COLOR.
- 9 4" SMOOTH FACED ECONOMY SIZED BRICK. SEE EXTERIOR FINISH SCHEDULE FOR COLOR.
- 10 STANDING SEAM METAL ROOF.
- 11 PRE-FINISHED METAL WALL PANELS (BY PEMB), REVERSE RIB PROFILE AT FRONT ELEVATION ONLY. SEE EXTERIOR FINISH SCHEDULE FOR COLOR.
- 12 PRE-FINISHED METAL WALL PANELS FOR SIDE AND REAR. PROVIDE TAMPER-RESISTANT FASTENERS FOR BOTTOM 8'-0". SEE EXTERIOR FINISH SCHEDULE FOR COLOR.
- 13 VENT FOR BATHROOM EXHAUST. REFER TO MECHANICAL DRAWING M1 FOR ADDITIONAL INFORMATION.
- 14 DOOR BUZZER. REFER TO ELECTRICAL DRAWING E1 FOR ADDITIONAL INFORMATION.
- 15 NOT USED.
- 16 HVAC UNITS MOUNTED ON ROOF. REFER TO MECHANICAL SHEET M1 FOR MORE INFORMATION.
- 17 OUTSIDE AIR TEMP. SENSOR MOUNTED OVER RECEIVING DOOR AT 9'-0" A.F.F.
- 18 MINIMUM EAVE HEIGHT IS 14'-0" A.F.F.
- 19 PARAPET BEYOND.
- 20 IN NORTHERN CLIMATES, PROVIDE SNOW GUARDS ON ROOF PER LOCAL CODE.
- 21 EXTEND PARAPET WALL UP AS NEEDED TO SCREEN ROOF MOUNTED EQUIPMENT IF REQUIRED BY LOCAL ORDINANCE.
- 22 FINISH GRADE TO BE A MINIMUM OF 6" BELOW FINISHED FLOOR LEVEL AT ALL NONPAVED AREAS.
- 23 NOT USED.
- 24 1/2" DIAMETER x 6" LONG STEEL EYE BOLTS (CLOSED) WITH 1" DIAMETER OPENINGS. DRILL AND EPOXY INTO BLOCK WALL. 4 BOLTS TO BE LOCATED AS SHOWN EACH SIDE OF ENTRY. TOTAL OF 8 BOLTS.

REVISIONS:



THESE DOCUMENTS ARE PROVIDED AS A DESIGN CRITERIA TEMPLATE FOR THIS BUILDING TYPE. THESE DRAWINGS MUST BE REVIEWED AND ADAPTED BY A LICENSED ARCHITECT AND ENGINEER TO COMPLY WITH THE REQUIREMENTS OF ALL FEDERAL, STATE AND LOCAL AUTHORITIES FOR SITE SPECIFIC PROJECTS. ALL PROJECTS MUST BE APPROVED BY DOLLAR GENERAL PRIOR TO START OF CONSTRUCTION.

**STORE NUMBER**  
**STREET ADDRESS**  
**CITY - STATE**

**DOLLAR GENERAL**  
PROTOTYPE CRITERIA SET PLAN  
80'-0" X 156'-0" 12,480 SF PROTOTYPE DGPM "B"  
ARCHITECTURAL AND ENGINEERING DEPARTMENT (615) 855-4753  
BTSPLANS@DOLLARGENERAL.COM

DATE:  
FEBRUARY 1, 2023  
DRAWING TITLE:  
EXTERIOR ELEVATIONS  
SCALE:  
1/8" = 1'-0"  
SHEET NO.

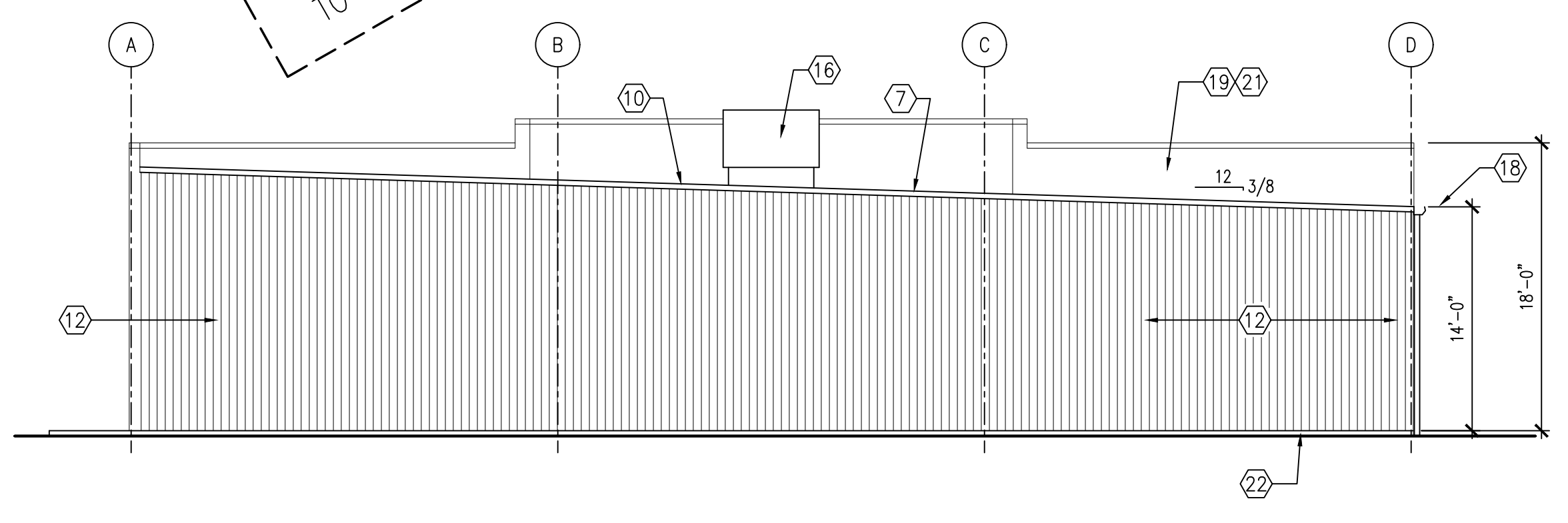
A2



2 REAR ELEVATION  
SCALE: 1/8" = 1'-0"

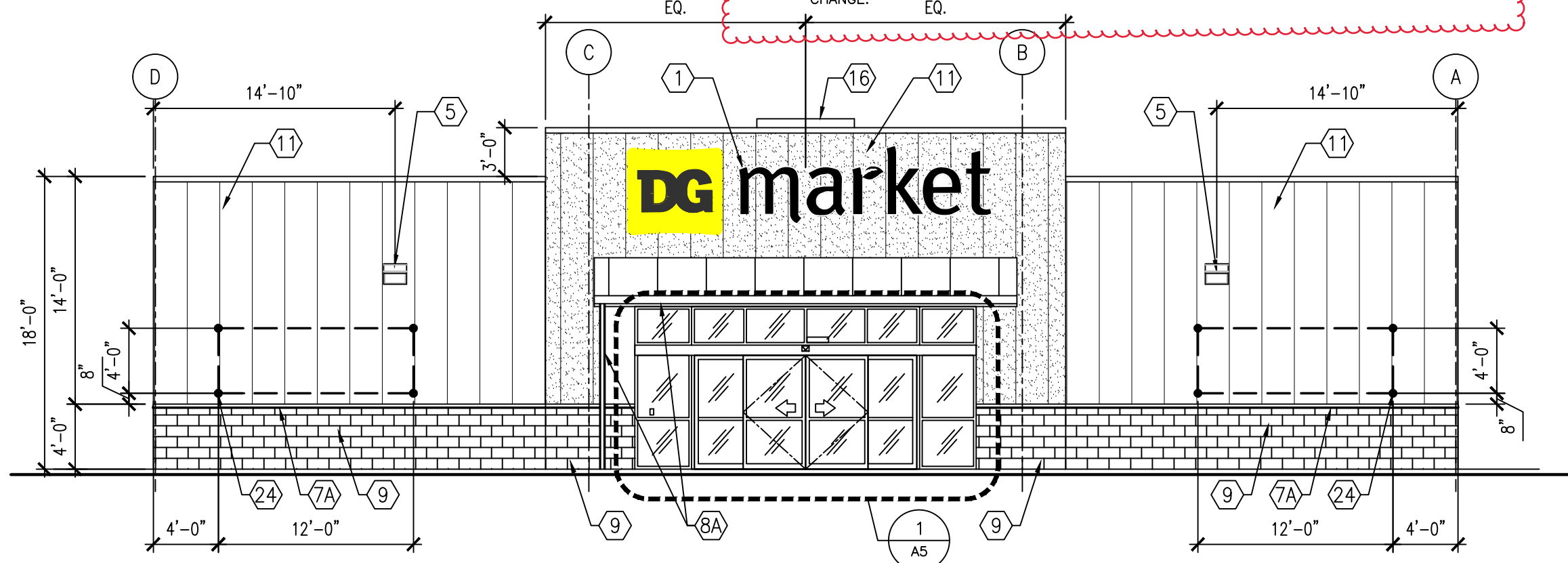

1 FRONT ELEVATION  
SCALE: 1/8" = 1'-0"

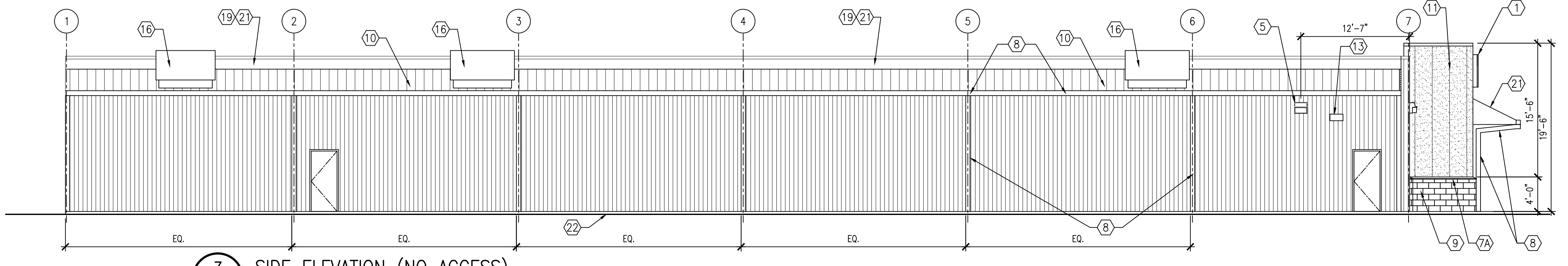

3 SIDE ELEVATION (NO ACCESS)  
SCALE: 1/8" = 1'-0"

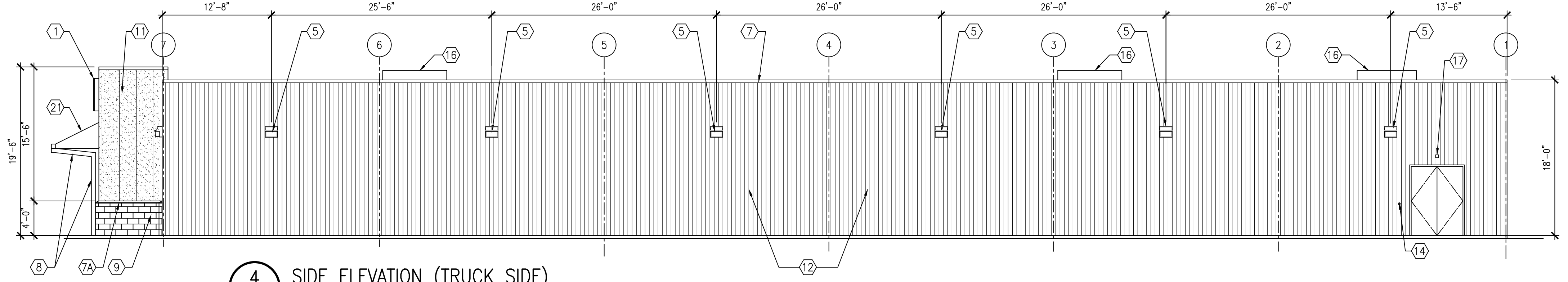

4 SIDE ELEVATION (TRUCK SIDE)  
SCALE: 1/8" = 1'-0"